

## Low-power single CMOS timer

Datasheet - production data

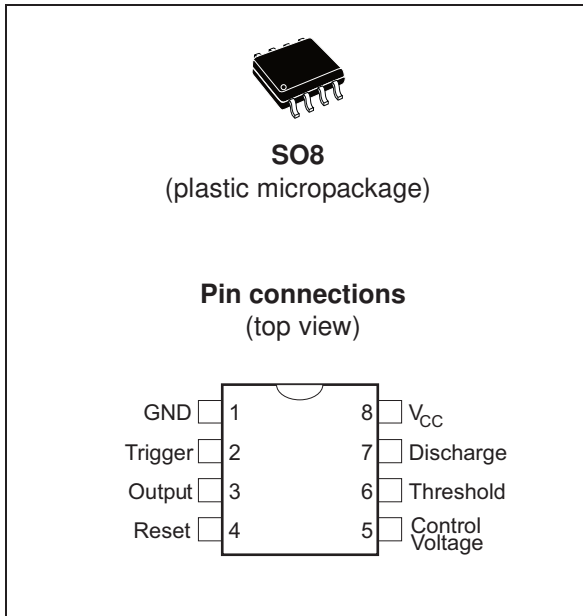

### Description

The TS555 is a single CMOS timer with very low consumption:

( $I_{CC(TYP)}$  TS555 = 110  $\mu$ A at  $V_{CC} = +5$  V versus  $I_{CC(TYP)}$  NE555<sup>(a)</sup> = 3 mA),

and high frequency:

( $f_{f(max.)}$  TS555 = 2.7 MHz versus  $f_{(max)}$  NE555<sup>(a)</sup> = 0.1 MHz).

Timing remains accurate in both monostable and astable mode.

The TS555 provides reduced supply current spikes during output transitions, which enable the use of lower decoupling capacitors compared to those required by bipolar NE555<sup>(a)</sup>.

With the high input impedance ( $10^{12}\Omega$ ), timing capacitors can also be minimized.

### Features

- Very low power consumption:
  - 110  $\mu$ A typ at  $V_{CC} = 5$  V
  - 90  $\mu$ A typ at  $V_{CC} = 3$  V
- High maximum astable frequency of 2.7 MHz
- Pin-to-pin functionally-compatible with bipolar NE555<sup>(a)</sup>
- Wide voltage range: +2 V to +16 V
- Supply current spikes reduced during output transitions
- High input impedance:  $10^{12}\Omega$
- Output compatible with TTL, CMOS and logic MOS

a. Terminated product

---

# Contents

|          |  |           |
|----------|--|-----------|
| <b>1</b> | <b>Absolute maximum ratings and operating conditions</b> ..... | <b>3</b>  |
| <b>2</b> | <b>Schematic diagrams</b> .....                                | <b>4</b>  |
| <b>3</b> | <b>Electrical characteristics</b> .....                        | <b>6</b>  |
| <b>4</b> | <b>Application information</b> .....                           | <b>13</b> |
|          | 4.1 Monostable operation .....                                 | 13        |
|          | 4.2 Astable operation .....                                    | 14        |
| <b>5</b> | <b>Package information</b> .....                               | <b>15</b> |
|          | 5.1 SO8 package information .....                              | 16        |
| <b>6</b> | <b>Ordering information</b> .....                              | <b>17</b> |
| <b>7</b> | <b>Revision history</b> .....                                  | <b>18</b> |

# 1 Absolute maximum ratings and operating conditions

**Table 1. Absolute maximum ratings**

| Symbol     | Parameter   | Value       | Unit |
|------------|---|-------------|------|
| $V_{CC}$   | Supply voltage  | +18         | V    |
| $I_{OUT}$  | Output current  | $\pm 100$   | mA   |
| $R_{thja}$ | Thermal resistance junction to ambient <sup>(1)</sup> | 125         | °C/W |
| $R_{thjc}$ | Thermal resistance junction to case <sup>(1)</sup>    | 40          |      |
| $T_j$      | Junction temperature                                  | +150        | °C   |
| $T_{stg}$  | Storage temperature range                             | -65 to +150 |      |
| ESD        | Human body model (HBM) <sup>(2)</sup>                 | 1500        | V    |
|            | Machine model (MM) <sup>(3)</sup>                     | 200         |      |
|            | Charged device model (CDM) <sup>(4)</sup>             | 1000        |      |

1. Short-circuits can cause excessive heating. These values are typical and specified for a four layers PCB.
2. Human body model: a 100 pF capacitor is charged to the specified voltage, then discharged through a 1.5k $\Omega$  resistor between two pins of the device. This is done for all couples of connected pin combinations while the other pins are floating.
3. Machine model: a 200 pF capacitor is charged to the specified voltage, then discharged directly between two pins of the device with no external series resistor (internal resistor < 5  $\Omega$ ). This is done for all couples of connected pin combinations while the other pins remain floating.
4. Charged device model: all pins plus package are charged together to the specified voltage and then discharged directly to the ground.

**Table 2. Operating conditions**

| Symbol     | Parameter                            | Value       | Unit |
|------------|--------------------------------------|-------------|------|
| $V_{CC}$   | Supply voltage                       | 2 to 16     | V    |
| $I_{OUT}$  | Output sink current                  | 50          | mA   |
|            | Output source current                | 10          |      |
| $T_{oper}$ | Operating free air temperature range | -40 to +125 | °C   |

## 2 Schematic diagrams

Figure 1. Schematic diagram

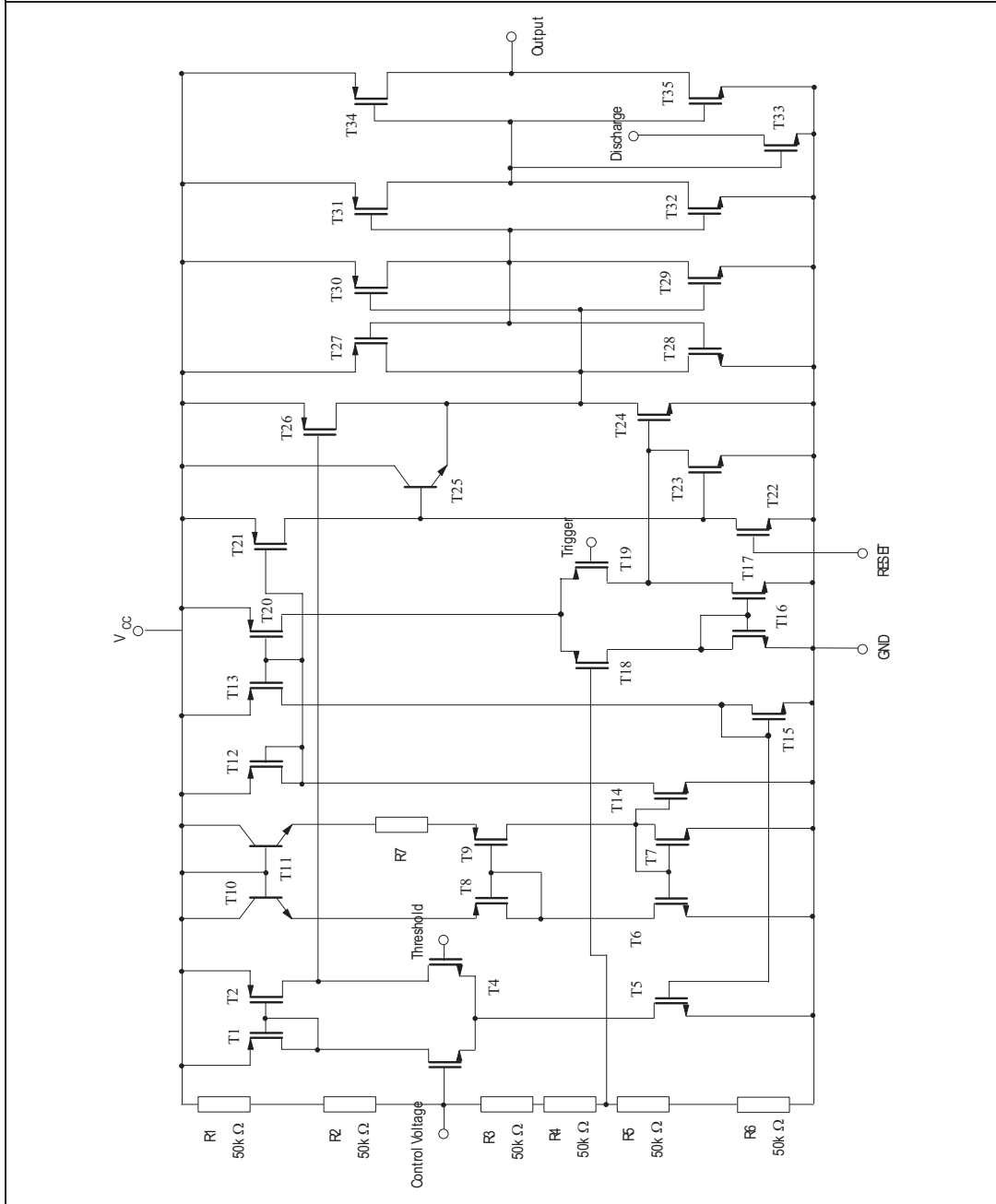

Figure 2. Block diagram

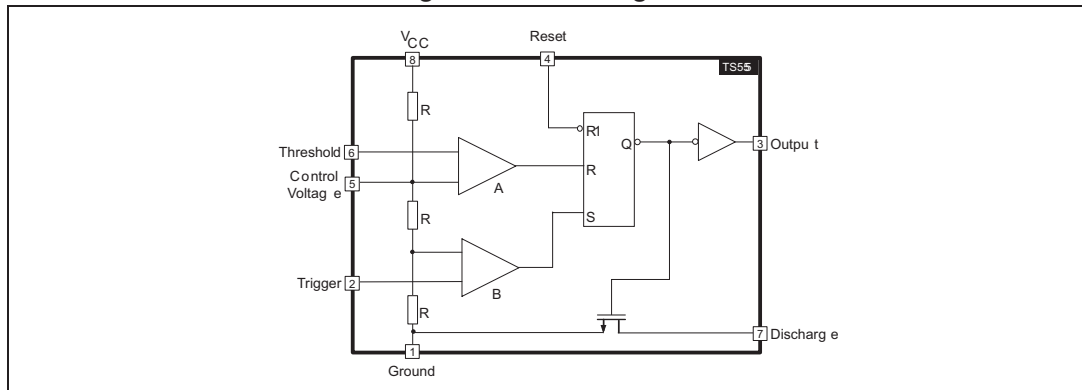

Table 3. Functional table

| Reset | Trigger | Threshold | Output         |
|-------|---------|-----------|----------------|
| Low   | x       | x         | Low            |
| High  | Low     |           | High           |
|       | High    | High      | Low            |
|       |         | Low       | Previous state |

Note:  
 Low: level voltage  $\leq$  minimum voltage specified  
 High: level voltage  $\geq$  maximum voltage specified  
 x: irrelevant

### 3 Electrical characteristics

**Table 4. Static electrical characteristics**  
 $V_{CC} = +2\text{ V}$ ,  $T_{amb} = +25\text{ °C}$ , reset to  $V_{CC}$  (unless otherwise specified)

| Symbol      | Parameter  | Min.       | Typ. | Max.         | Unit          |
|-------------|--|------------|------|--------------|---------------|
| $I_{CC}$    | Supply current (no load, high and low states)<br>$T_{min} \leq T_{amb} \leq T_{max}$               |            | 65   | 200<br>200   | $\mu\text{A}$ |
| $V_{CL}$    | Control voltage level<br>$T_{min} \leq T_{amb} \leq T_{max}$                                       | 1.2<br>1.1 | 1.3  | 1.4<br>1.5   | V             |
| $V_{DIS}$   | Discharge saturation voltage ( $I_{dis} = 1\text{ mA}$ )<br>$T_{min} \leq T_{amb} \leq T_{max}$    |            | 0.05 | 0.2<br>0.25  |               |
| $I_{DIS}$   | Discharge pin leakage current  |            | 1    | 100          | nA            |
| $V_{OL}$    | Low level output voltage ( $I_{sink} = 1\text{ mA}$ )<br>$T_{min} \leq T_{amb} \leq T_{max}$       |            | 0.1  | 0.3<br>0.35  | V             |
| $V_{OH}$    | High level output voltage ( $I_{source} = -0.3\text{ mA}$ )<br>$T_{min} \leq T_{amb} \leq T_{max}$ | 1.5<br>1.5 | 1.9  |              |               |
| $V_{TRIG}$  | Trigger voltage<br>$T_{min} \leq T_{amb} \leq T_{max}$   | 0.4<br>0.3 | 0.67 | 0.95<br>1.05 |               |
| $I_{TRIG}$  | Trigger current  |            | 10   |              | pA            |
| $I_{TH}$    | Threshold current  |            | 10   |              |               |
| $V_{RESET}$ | Reset voltage<br>$T_{min} \leq T_{amb} \leq T_{max}$   | 0.4<br>0.3 | 1.1  | 1.5<br>2.0   | V             |
| $I_{RESET}$ | Reset current  |            | 10   |              | pA            |

**Table 5. Static electrical characteristics**  
 **$V_{CC} = +3\text{ V}$ ,  $T_{amb} = +25\text{ °C}$ , reset to  $V_{CC}$  (unless otherwise specified)**

| Symbol      | Parameter  | Min.       | Typ. | Max.        | Unit          |
|-------------|--|------------|------|-------------|---------------|
| $I_{CC}$    | Supply current (no load, high and low states)<br>$T_{min} \leq T_{amb} \leq T_{max}$               |            | 90   | 230<br>230  | $\mu\text{A}$ |
| $V_{CL}$    | Control voltage level<br>$T_{min} \leq T_{amb} \leq T_{max}$                                       | 1.8<br>1.7 | 2    | 2.2<br>2.3  | V             |
| $V_{DIS}$   | Discharge saturation voltage ( $I_{dis} = 1\text{ mA}$ )<br>$T_{min} \leq T_{amb} \leq T_{max}$    |            | 0.05 | 0.2<br>0.25 |               |
| $I_{DIS}$   | Discharge pin leakage current  |            | 1    | 100         | nA            |
| $V_{OL}$    | Low level output voltage ( $I_{sink} = 1\text{ mA}$ )<br>$T_{min} \leq T_{amb} \leq T_{max}$       |            | 0.1  | 0.3<br>0.35 | V             |
| $V_{OH}$    | High level output voltage ( $I_{source} = -0.3\text{ mA}$ )<br>$T_{min} \leq T_{amb} \leq T_{max}$ | 2.5<br>2.5 | 2.9  |             |               |
| $V_{TRIG}$  | Trigger voltage<br>$T_{min} \leq T_{amb} \leq T_{max}$   | 0.9<br>0.8 | 1    | 1.1<br>1.2  |               |
| $I_{TRIG}$  | Trigger current  |            | 10   |             | pA            |
| $I_{TH}$    | Threshold current  |            | 10   |             |               |
| $V_{RESET}$ | Reset voltage<br>$T_{min} \leq T_{amb} \leq T_{max}$   | 0.4<br>0.3 | 1.1  | 1.5<br>2.0  | V             |
| $I_{RESET}$ | Reset current  |            | 10   |             | pA            |

**Table 6. Dynamic electrical characteristics**  
 $V_{CC} = +3\text{ V}$ ,  $T_{amb} = +25\text{ °C}$ , reset to  $V_{CC}$  (unless otherwise specified)

| Symbol    | Parameter  | Min. | Typ.   | Max. | Unit   |
|-----------|--|------|--------|------|--------|
|           | Timing accuracy (monostable) <sup>(1)</sup><br>$R = 10\text{ k}\Omega$ , $C = 0.1\text{ }\mu\text{F}$<br>$V_{CC} = 2\text{ V}$<br>$V_{CC} = 3\text{ V}$  |      | 1<br>1 |      | %      |
|           | Timing shift with supply voltage variations (monostable)<br>$R = 10\text{ k}\Omega$ , $C = 0.1\text{ }\mu\text{F}$ , $V_{CC} = 3\text{ V} \pm 0.3\text{ V}$ <sup>(1)</sup>                           |      | 0.5    |      | %/V    |
|           | Timing shift with temperature <sup>(1)</sup><br>$T_{min} \leq T_{amb} \leq T_{max}$  |      | 75     |      | ppm/°C |
| $f_{max}$ | Maximum astable frequency <sup>(2)</sup><br>$R_A = 470\text{ }\Omega$ , $R_B = 200\text{ }\Omega$ , $C = 200\text{ pF}$  | —    | 2      | —    | MHz    |
|           | Astable frequency accuracy <sup>(2)</sup><br>$R_A = R_B = 1\text{ k}\Omega$ to $100\text{ k}\Omega$ , $C = 0.1\text{ }\mu\text{F}$   |      | 5      |      | %      |
|           | Timing shift with supply voltage variations (astable mode) <sup>(2)</sup><br>$R_A = R_B = 1\text{ k}\Omega$ to $100\text{ k}\Omega$ , $C = 0.1\text{ }\mu\text{F}$ ,<br>$V_{CC} = 3$ to $5\text{ V}$ |      | 0.5    |      | %/V    |
| $t_R$     | Output rise time ( $C_{load} = 10\text{ pF}$ )   |      | 25     |      | ns     |
| $t_F$     | Output fall time ( $C_{load} = 10\text{ pF}$ )   |      | 20     |      |        |
| $t_{PD}$  | Trigger propagation delay  |      | 100    |      |        |
| $t_{RPW}$ | Minimum reset pulse width ( $V_{trig} = 3\text{ V}$ )  |      | 350    |      |        |

1. See [Figure 4](#)

2. See [Figure 6](#)



**Table 7. Static electrical characteristics**  
 **$V_{CC} = +5\text{ V}$ ,  $T_{amb} = +25\text{ °C}$ , reset to  $V_{CC}$  (unless otherwise specified)**

| Symbol      | Parameter  | Min.         | Typ. | Max.         | Unit          |
|-------------|--|--------------|------|--------------|---------------|
| $I_{CC}$    | Supply current (no load, high and low states)<br>$T_{min} \leq T_{amb} \leq T_{max}$             |              | 110  | 250<br>250   | $\mu\text{A}$ |
| $V_{CL}$    | Control voltage level<br>$T_{min} \leq T_{amb} \leq T_{max}$                                     | 2.9<br>2.8   | 3.3  | 3.8<br>3.9   | V             |
| $V_{DIS}$   | Discharge saturation voltage ( $I_{dis} = 10\text{ mA}$ )<br>$T_{min} \leq T_{amb} \leq T_{max}$ |              | 0.2  | 0.3<br>0.35  |               |
| $I_{DIS}$   | Discharge pin leakage current  |              | 1    | 100          | nA            |
| $V_{OL}$    | Low level output voltage ( $I_{sink} = 8\text{ mA}$ )<br>$T_{min} \leq T_{amb} \leq T_{max}$     |              | 0.3  | 0.6<br>0.8   | V             |
| $V_{OH}$    | High level output voltage ( $I_{source} = -2\text{ mA}$ )<br>$T_{min} \leq T_{amb} \leq T_{max}$ | 4.4<br>4.4   | 4.6  |              |               |
| $V_{TRIG}$  | Trigger voltage<br>$T_{min} \leq T_{amb} \leq T_{max}$   | 1.36<br>1.26 | 1.67 | 1.96<br>2.06 |               |
| $I_{TRIG}$  | Trigger current  |              | 10   |              | pA            |
| $I_{TH}$    | Threshold current  |              | 10   |              |               |
| $V_{RESET}$ | Reset voltage<br>$T_{min} \leq T_{amb} \leq T_{max}$   | 0.4<br>0.3   | 1.1  | 1.5<br>2.0   | V             |
| $I_{RESET}$ | Reset current  |              | 10   |              | pA            |

**Table 8. Dynamic electrical characteristics**  
 $V_{CC} = +5\text{ V}$ ,  $T_{amb} = +25\text{ °C}$ , reset to  $V_{CC}$  (unless otherwise specified)

| Symbol    | Parameter   | Min. | Typ. | Max. | Unit   |
|-----------|---|------|------|------|--------|
|           | Timing accuracy (monostable) <sup>(1)</sup><br>R = 10 kΩ, C = 0.1 μF  | —    | 2    | —    | %      |
|           | Timing shift with supply voltage variations (monostable) <sup>(1)</sup><br>R = 10 kΩ, C = 0.1 μF, $V_{CC} = 5\text{ V} \pm 1\text{ V}$          |      | 0.38 |      | %/V    |
|           | Timing shift with temperature <sup>(1)</sup><br>$T_{min} \leq T_{amb} \leq T_{max}^5$   |      | 75   |      | ppm/°C |
| $f_{max}$ | Maximum astable frequency <sup>(2)</sup><br>$R_A = 470\ \Omega$ , $R_B = 200\ \Omega$ , C = 200 pF  |      | 2.7  |      | MHz    |
|           | Astable frequency accuracy <sup>(2)</sup><br>$R_A = R_B = 1\text{ k}\Omega$ to 100 kΩ, C = 0.1 μF   |      | 3    |      | %      |
|           | Timing shift with supply voltage variations (astable mode) <sup>(2)</sup><br>$R_A = R_B = 10\text{ k}\Omega$ , C = 0.1 μF, $V_{CC} = 5$ to 12 V |      | 0.1  |      | %/V    |
| $t_R$     | Output rise time ( $C_{load} = 10\text{ pF}$ )  |      | 25   |      | ns     |
| $t_F$     | Output fall time ( $C_{load} = 10\text{ pF}$ )  |      | 20   |      |        |
| $t_{PD}$  | Trigger propagation delay   |      | 100  |      |        |
| $t_{RPW}$ | Minimum reset pulse width ( $V_{trig} = 5\text{ V}$ )   |      | 350  |      |        |

1. See [Figure 4](#)

2. See [Figure 6](#)

**Table 9. Static electrical characteristics**  
 $V_{CC} = +12\text{ V}$ ,  $T_{amb} = +25\text{ °C}$ , reset to  $V_{CC}$  (unless otherwise specified)

| Symbol      | Parameter   | Min.         | Typ. | Max.       | Unit          |
|-------------|---|--------------|------|------------|---------------|
| $I_{CC}$    | Supply current (no load, high and low states)<br>$T_{min} \leq T_{amb} \leq T_{max}$              |              | 170  | 400<br>400 | $\mu\text{A}$ |
| $V_{CL}$    | Control voltage level<br>$T_{min} \leq T_{amb} \leq T_{max}$                                      | 7.4<br>7.3   | 8    | 8.6<br>8.7 | V             |
| $V_{DIS}$   | Discharge saturation voltage ( $I_{dis} = 80\text{ mA}$ )<br>$T_{min} \leq T_{amb} \leq T_{max}$  |              | 0.09 | 1.5<br>2.0 |               |
| $I_{DIS}$   | Discharge pin leakage current   |              | 1    | 100        | nA            |
| $V_{OL}$    | Low level output voltage ( $I_{sink} = 50\text{ mA}$ )<br>$T_{min} \leq T_{amb} \leq T_{max}$     |              | 1.2  | 2<br>2.8   | V             |
| $V_{OH}$    | High level output voltage ( $I_{source} = -10\text{ mA}$ )<br>$T_{min} \leq T_{amb} \leq T_{max}$ | 10.5<br>10.5 | 11   |            |               |
| $V_{TRIG}$  | Trigger voltage<br>$T_{min} \leq T_{amb} \leq T_{max}$  | 3.2<br>3.1   | 4    | 4.8<br>4.9 |               |
| $I_{TRIG}$  | Trigger current   |              | 10   |            | pA            |
| $I_{TH}$    | Threshold current   |              | 10   |            |               |
| $V_{RESET}$ | Reset Voltage<br>$T_{min} \leq T_{amb} \leq T_{max}$  | 0.4<br>0.3   | 1.1  | 1.5<br>2.0 | V             |
| $I_{RESET}$ | Reset current   |              | 10   |            | pA            |

**Table 10. Dynamic electrical characteristics**  
 $V_{CC} = +12\text{ V}$ ,  $T_{amb} = +25\text{ }^\circ\text{C}$ , reset to  $V_{CC}$  (unless otherwise specified)

| Symbol           | Parameter  | Min. | Typ. | Max. | Unit   |
|------------------|--|------|------|------|--------|
|                  | Timing accuracy (monostable) <sup>(1)</sup><br>R = 10 kΩ, C = 0.1 μF, V <sub>CC</sub> = +12 V  | —    | 4    | —    | %      |
|                  | Timing shift with supply voltage variations (monostable) <sup>(1)</sup><br>R = 10 kΩ, C = 0.1 μF, V <sub>CC</sub> = +5 V ±1 V                            |      | 0.38 |      | %/V    |
|                  | Timing shift with temperature<br>T <sub>min</sub> ≤ T <sub>amb</sub> ≤ T <sub>max</sub> , V <sub>CC</sub> = +5 V   |      | 75   |      | ppm/°C |
| f <sub>max</sub> | Maximum astable frequency <sup>(2)</sup><br>R <sub>A</sub> = 470 Ω, R <sub>B</sub> = 200 Ω, C = 200 pF, V <sub>CC</sub> = +5 V                           |      | 2.7  |      | MHz    |
|                  | Astable frequency accuracy<br>R <sub>A</sub> = R <sub>B</sub> = 1 kΩ to 100 kΩ, C = 0.1 μF, V <sub>CC</sub> = +12 V                                      |      | 3    |      | %      |
|                  | Timing shift with supply voltage variations (astable mode)<br>R <sub>A</sub> = R <sub>B</sub> = 1 kΩ to 100 kΩ, C = 0.1 μF, V <sub>CC</sub> = 5 to +12 V |      | 0.1  |      | %/V    |

1. See [Figure 4](#)
2. See [Figure 6](#)

**Figure 3. Supply current (per timer) versus supply voltage**

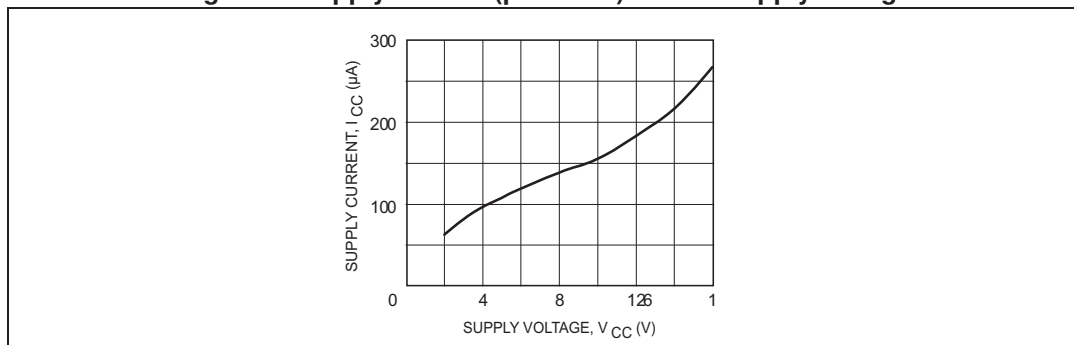

## 4 Application information

### 4.1 Monostable operation

In monostable mode, the timer operates like a one-shot generator. The external capacitor is initially held discharged by a transistor inside the timer, as shown in *Figure 4*.

**Figure 4. Application schematic**

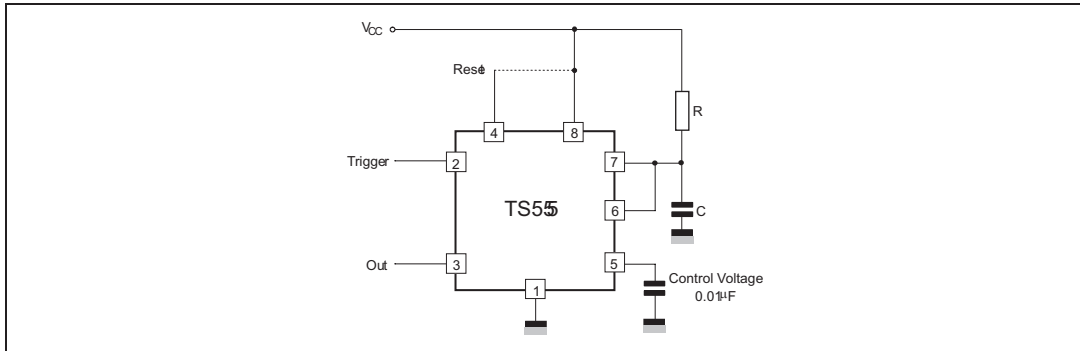

The circuit triggers on a negative-going input signal when the level reaches  $1/3 V_{CC}$ . Once triggered, the circuit remains in this state until the set time has elapsed, even if it is triggered again during this interval. The duration of the output HIGH state is given by  $t = 1.1 R \times C$ .

Since the charge rate and threshold level of the comparator are both directly proportional to the supply voltage, the timing interval is independent of the supply. Applying a negative pulse simultaneously to the reset terminal (pin 4) and the trigger terminal (pin 2) during the timing cycle discharges the external capacitor and causes the cycle to start over. The timing cycle then starts on the positive edge of the reset pulse. While the reset pulse is applied, the output is driven to the LOW state.

When a negative trigger pulse is applied to pin 2, the flip-flop is set, releasing the short circuit across the external capacitor and driving the output HIGH. The voltage across the capacitor increases exponentially with the time constant  $\tau = R \times C$ .

When the voltage across the capacitor equals  $2/3 V_{CC}$ , the comparator resets the flip-flop which then discharges the capacitor rapidly and drives the output to its LOW state. *Figure 5* shows the actual waveforms generated in this mode of operation.

When reset is not used, it should be tied high to avoid any false triggering.

**Figure 5. Timing diagram**

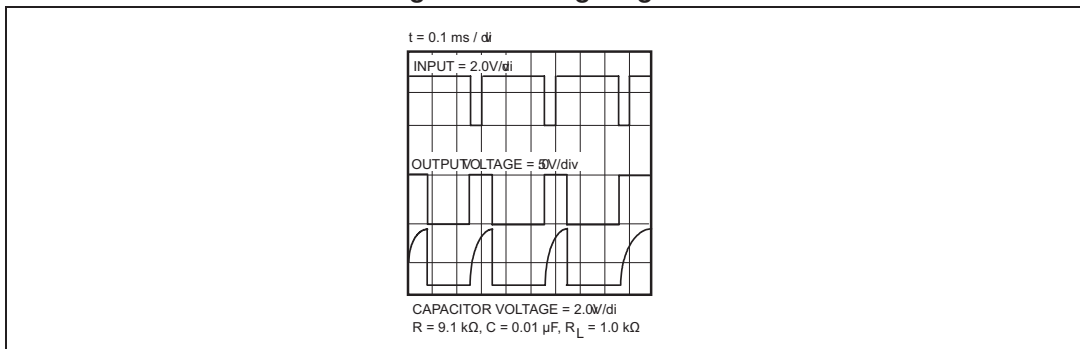

## 4.2 Astable operation

When the circuit is connected as shown in *Figure 6* (pins 2 and 6 connected) it triggers itself and runs as a multi-vibrator. The external capacitor charges through  $R_A$  and  $R_B$  and discharges through  $R_B$  only. Therefore, the duty cycle may be precisely set by the ratio of these two resistors.

In the astable mode of operation, C charges and discharges between  $1/3 V_{CC}$  and  $2/3 V_{CC}$ . As in the triggered mode, the charge and discharge times, and therefore frequency, are independent of the supply voltage.

**Figure 6. Application schematic**

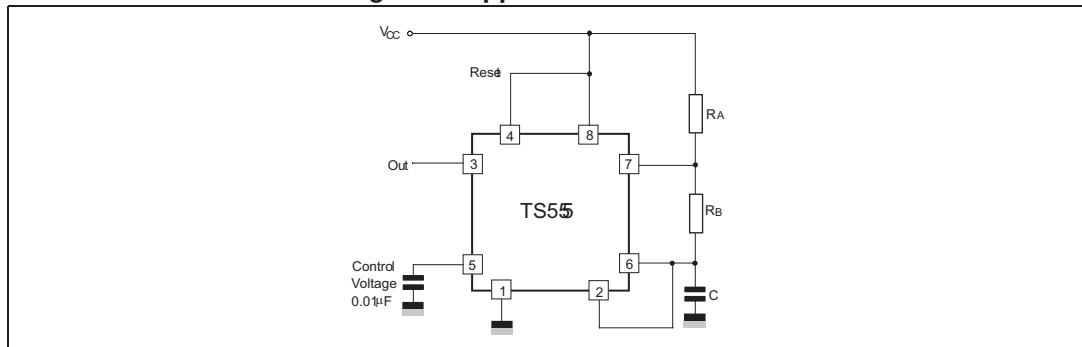

*Figure 7* shows actual waveforms generated in this mode of operation.

The charge time (output HIGH) is given by:

$$t1 = 0.693 (R_A + R_B) C$$

The discharge time (output LOW) by:

$$t2 = 0.693 \times R_B \times C$$

Thus the total period T is given by:

$$T = t1 + t2 = 0.693 (R_A + 2R_B) C$$

The frequency of oscillation is then:

$$f = \frac{1}{T} = \frac{1.44}{(R_A + 2R_B)C}$$

The duty cycle is given by:

$$D = \frac{R_B}{R_A + 2R_B}$$

**Figure 7. Timing diagram**

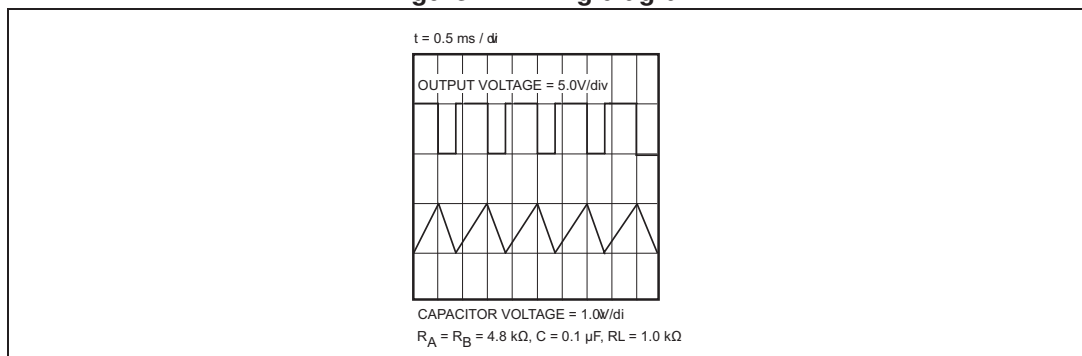

## 5 Package information

In order to meet environmental requirements, ST offers these devices in different grades of ECOPACK packages, depending on their level of environmental compliance. ECOPACK specifications, grade definitions and product status are available at: [www.st.com](http://www.st.com). ECOPACK is an ST trademark.

### 5.1 SO8 package information

Figure 8. SO8 package outline

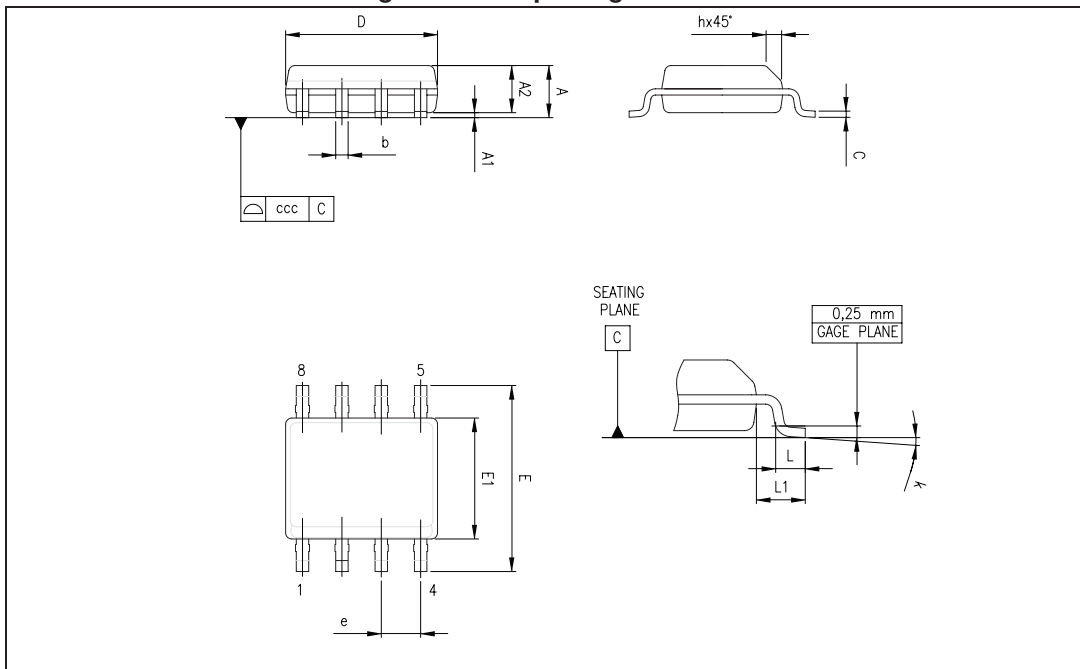

Table 11. SO8 mechanical data

| Ref. | Dimensions  |      |      |        |       |       |
|------|-------------|------|------|--------|-------|-------|
|      | Millimeters |      |      | Inches |       |       |
|      | Min.        | Typ. | Max. | Min.   | Typ.  | Max.  |
| A    |             |      | 1.75 |        |       | 0.069 |
| A1   | 0.10        |      | 0.25 | 0.004  |       | 0.010 |
| A2   | 1.25        |      |      | 0.049  |       |       |
| b    | 0.28        |      | 0.48 | 0.011  |       | 0.019 |
| c    | 0.17        |      | 0.23 | 0.007  |       | 0.010 |
| D    | 4.80        | 4.90 | 5.00 | 0.189  | 0.193 | 0.197 |
| E    | 5.80        | 6.00 | 6.20 | 0.228  | 0.236 | 0.244 |
| E1   | 3.80        | 3.90 | 4.00 | 0.150  | 0.154 | 0.157 |
| e    |             | 1.27 |      |        | 0.050 |       |
| h    | 0.25        |      | 0.50 | 0.010  |       | 0.020 |
| L    | 0.40        |      | 1.27 | 0.016  |       | 0.050 |
| L1   |             | 1.04 |      |        | 0.040 |       |
| k    | 1°          |      | 8°   | 1°     |       | 8°    |
| ccc  |             |      | 0.10 |        |       | 0.004 |



## 6 Ordering information

Table 12. Order code table

| Order code | Temperature range | Package | Packaging     | Marking |
|------------|-------------------|---------|---------------|---------|
| TS555IDTTR | -40 °C to 125 °C  | SO8     | Tape and reel | 555I    |

## 7 Revision history

**Table 13. Document revision history**

| Date        | Revision | Changes  |
|-------------|----------|--|
| 01-Feb-2003 | 1        | Initial release.   |
| 03-Nov-2008 | 2        | Document reformatted.<br>Added output current, ESD and thermal resistance values in Table 1: Absolute maximum ratings.<br>Added output current values in Table 2: Operating conditions.  |
| 29-Aug-2014 | 3        | Section 5: Package information: updated corporate text<br>Replaced Table 15: Ordering information scheme.  |
| 24-Jun-2015 | 4        | Features and Description: added footnote to NE555 product to explain it is terminated.<br>Removed all references to DIP8 and TSSOP8 packages<br>Removed all temperature ranges except -40 to 125 °C<br>Replaced Table 15: Ordering information scheme with Table 12: Order code table. |
| 13-Jan-2025 | 5        | Updated I <sub>OUT</sub> value in <a href="#">Table 2</a> .  |

**IMPORTANT NOTICE – PLEASE READ CAREFULLY**

STMicroelectronics NV and its subsidiaries (“ST”) reserve the right to make changes, corrections, enhancements, modifications, and improvements to ST products and/or to this document at any time without notice. Purchasers should obtain the latest relevant information on ST products before placing orders. ST products are sold pursuant to ST’s terms and conditions of sale in place at the time of order acknowledgement.

Purchasers are solely responsible for the choice, selection, and use of ST products and ST assumes no liability for application assistance or the design of Purchasers’ products.

No license, express or implied, to any intellectual property right is granted by ST herein.

Resale of ST products with provisions different from the information set forth herein shall void any warranty granted by ST for such product.

ST and the ST logo are trademarks of ST. For additional information about ST trademarks, please refer to [www.st.com/trademarks](http://www.st.com/trademarks). All other product or service names are the property of their respective owners.

Information in this document supersedes and replaces information previously supplied in any prior versions of this document.

© 2025 STMicroelectronics – All rights reserved