

CMT802XNXL High-Speed, Dual-Channel Digital Isolator

1 Features

- Safety-related certifications
 - DIN VDE V 0884-11: 2017-01
 - UL 1577 component recognition program
 - CSA certification according to IEC 60950-1, IEC 62368-1, IEC 61010-1 and IEC 60601-1 end equipment standards
 - CQC approval per GB4943.1-2022
 - TUV certification according to EN 60950-1, EN 62368-1 and EN 61010-1
- Robust electromagnetic compatibility
 - System-level ESD, EFT, and surge immunity
 - ± 8 kV IEC 61000-4-2 contact discharge protection across isolation barrier
 - Low emissions
- Data rate: up to 10 Mbps
- Wide supply range: 2.5 to 5.5 V
- Operation temperature: -40°C to 125°C
- Robust isolation barrier
 - More than 40-year projected lifetime
 - Up to 3.75 kV_{RMS} isolation rating
 - Up to 5.3 kV surge capability
 - ± 200 kV/ μs typical CMTI
- Default output high or low options
- Low power consumption, typical 1.5 mA per channel at 1 Mbps
- Low propagation delay: 9 ns typical (5V supplies)
- SOIC 8 package (narrow body)

2 Applications

- Industrial automatic control
- New energy vehicles
- Solar inverters
- Motor control
- Isolated SPI
- General purpose multichannel isolation

3 Description

The CMT802XNXL series devices are high-performance, dual channel digital isolators with as high as 3.75 kV_{rms} isolation voltage by means of silicon-dioxide (SiO₂) insulation barrier.

The digital isolator is used to communicate between two different power supply domains while prevents noise currents on a data bus or other circuits from entering the local ground and interfering with or damaging sensitive circuitry.

This device comes with enable pins that can be used to put the respective outputs in high impedance for multi-master driving applications and to reduce power consumption. The CMT802XNXL device has four forward and up to two reverse-direction channels. If the input power or signal is lost, the default output is high for the CMT802XN1L device and low for the CMT802XN0L device. See the Device Functional Modes section for further details.

The isolator provides high electromagnetic immunity and low emissions at low-power consumption. Through innovative chip design and layout techniques, electromagnetic compatibility of the CMT802XNXL device has been significantly enhanced to ease system-level ESD, EFT, surge, and emissions compliance.

The CMT802XNXL series device is available in narrow-body (NB) 8-pin SOIC package.

Device Information

Part No.	Package	Body Size (mm x mm)
CMT802XNXL	NB(N) SOIC-8	5.0 x 3.9
Refer to section 14 for ordering information.		

Simplified Schematic

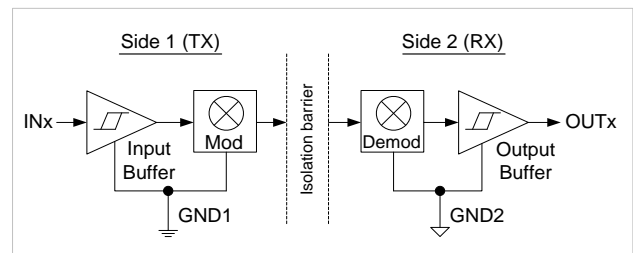

Table of Contents

1 Features	1
2 Applications	1
3 Description	1
4 Absolute Maximum Ratings	3
5 Recommended Operating Conditions	3
6 ESD Ratings	4
7 Pin Description	5
8 Typical Application	6
8.1 Typical Application Schematic.....	6
8.2 PCB Layout Guidelines.....	6
9 Parameter Measurement Circuit Setup	7
10 Electrical Specifications	8
10.1 Electrical Characteristics with 5 V Supply.....	8
10.2 Supply Current Characteristics with 5 V Supply.....	8
10.3 Supply Current Characteristics with 3.3 V Supply.....	9
10.4 Supply Current Characteristics with 2.5 V Supply.....	10
10.6 Insulation Specifications.....	14
10.7 Safety-related Certifications.....	16
10.8 Safety Limiting Values.....	16
10.9 Thermal Information.....	17
11 Function Description	18
11.1 Function Overview.....	18
11.2 Functional Modes.....	18
11.3 Insulation Lifetime.....	18
12 Packaging Information	20
12.1 CMT802XNXL Narrow Body SOIC-8 Packaging.....	20
13 Ordering Information	21
14 Tape and Reel Information	22
15 Revise History	24
16 Contacts	25

4 Absolute Maximum Ratings

Table 1. Absolute Maximum Ratings^[1]

Parameters	Symbol	Condition	Min.	Max.	Unit
Power supply voltage ^[2]	VDD1, VDD2		-0.5	6.5	V
Maximum input voltage	INx	x = A, B	-0.4	VDD+0.4	V
Maximum output voltage	OUTx	x = A, B	-0.4	VDD+0.4	V
Maximum Input / output pulse voltage	-	Pulse width should be less than 100 ns, and the duty cycle should be less than 10%	-0.8	VDD+0.8	V
Common-mode transient immunity	CMTI			±200	kV/us
Output current	I _O		-15	15	mA
Maximum surge immunity	-			5.3	kV
Operating temperature	T _A		-40	125	°C
Storage temperature	T _{STG}		-40	150	°C

Notes:

- [1]. Stresses beyond those listed under Absolute Maximum Ratings may cause permanent damage to the device. These are stress ratings only and functional operation of the device at these or any other conditions beyond those indicated under Recommended Operating Conditions is not implied. Exposure to absolute maximum rated conditions for extended periods may affect device reliability.
- [2]. All voltage values except differential I/O bus voltages are with respect to the local ground terminal (GND1 or GND2) and are peak voltage values.

5 Recommended Operating Conditions

Table 2. Recommended Operating Conditions

Parameters	Symbol	Condition	Min.	Typ.	Max.	Unit
Power supply voltage	VDD1, VDD2		2.5	5	5.5	V
High level input voltage	V _{IH}	VDDI: input side VDD	0.7*VDD		VDDI	V
Low level input voltage	V _{IL}	VDDI: input side VDD	0		0.3VDD	V
Data rate	DR		0		5	Mbps
Operating temperature	T _A		-40	25	125	°C
Junction temperature	T _J		-40		150	°C

6 ESD Ratings

Table 3. ESD Ratings

Parameter	Symbol	Condition	Max.	Unit
Electrostatic discharge	V _{ESD}	Human-body model (HBM)	±8000	V
		Charged-device model (CDM)	± 2000	

Notes:

- IEC ESD strike is applied across the barrier with all pins on each side tied together creating a two-terminal device.
- Testing is carried out in air or oil to determine the intrinsic contact discharge capability of the device.

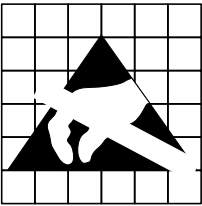

Caution! ESD sensitive device. Precaution should be used when handling the device in order to prevent performance degradation or loss of functionality.

7 Pin Description

The series part number CMT8020NXL, CMT8021NXL and CMT8022NXL are available for narrow-body (N) 8-pin SOIC package. The pin lists are shown as below.

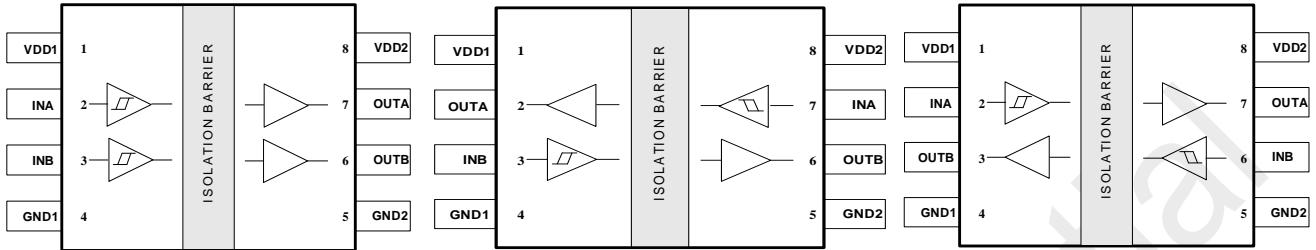

Figure 1. CMT8020NXL Pin List

Figure 2. CMT8021NXL Pin List

Figure 3. CMT8022NXL Pin List

Table 4. CMT8020 / 21 / 22NXL Pin Description

Pin Name	Pin Number			I/O	Description
	NB SOIC-8				
	CMT8120N	CMT8121N	CMT8122N		
GND1	4	4	4	-	Left ground
GND2	5	5	5	-	Right ground
INA	2	7	2	I	Input, channel A
INB	3	3	6	I	Input, channel B
NC	-	-	-	-	Disconnect / connect to the GND
OUTA	7	2	7	O	Output, channel A
OUTB	6	6	3	O	Output, channel B
VDD1	1	1	1	-	Power supply for left side
VDD2	8	8	8	-	Power supply for right side

8 Typical Application

8.1 Typical Application Schematic

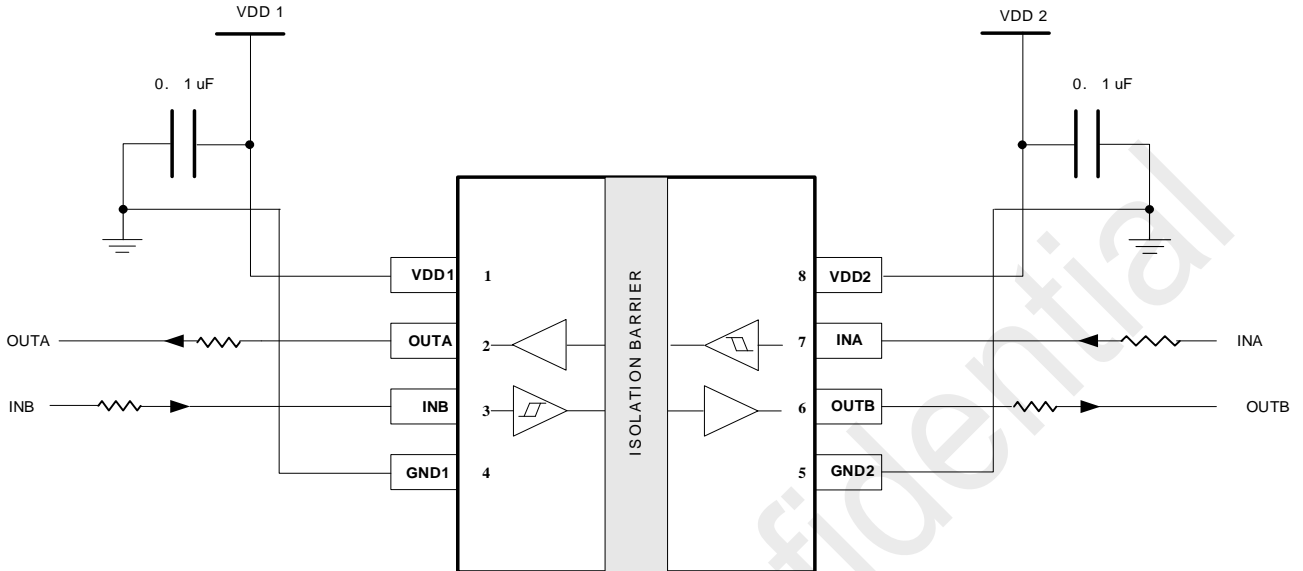

Figure 7. Typical Application Schematic (Take the CMT8021NXL as an example)

Note: users should be careful not to connect ground and VDD reversely

8.2 PCB Layout Guidelines

The CMT802XNXL requires a 0.1 μF bypass capacitor in both input side and output side. The capacitor should be placed as close as possible to the package pin of VDD1 and VDD2 respectively. The figures below show the recommended PCB layout. Please make sure the space under the chip keeps free from planes, traces, pads and via. To enhance the robustness of design, users may also include resistors (50 ~ 300 Ω) in series with the inputs and outputs if the system is excessively noisy. The series resistors also improve the system reliability such as latch-up immunity.

The typical output impedance of an isolator driver channel is approximately $50 \Omega \pm 40\%$. When driving loads where transmission line effects will be a factor, output pins should be appropriately terminated with controlled impedance PCB traces.

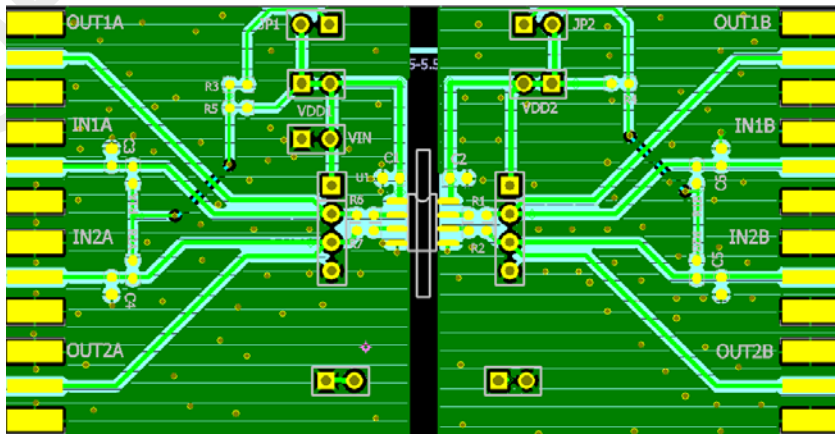

Figure 8. Recommended PCB Layout

9 Parameter Measurement Circuit Setup

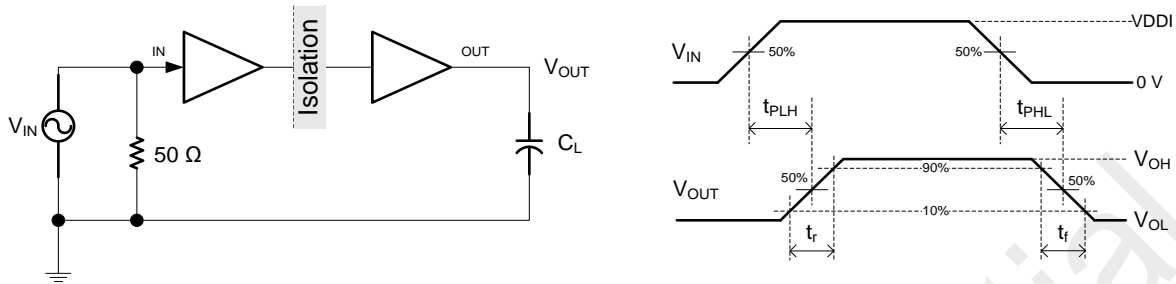

Figure 9. Switching Characteristics Test Circuit and Voltage Waveforms

Notes:

1. The input pulse is supplied by a generator V_{IN} having the following characteristics: $f_{PULSE} \leq 100$ kHz, 50% duty cycle, $t_r \leq 3$ ns, $t_f \leq 3$ ns, $Z_O = 50 \Omega$. At the input, 50Ω resistor is required to terminate input generator signal. It is not needed in actual application.
2. Load capacitance influences the measurement results quite a lot, including instrumentation and fixture capacitance, totally no more than 15 pF loading is preferred.

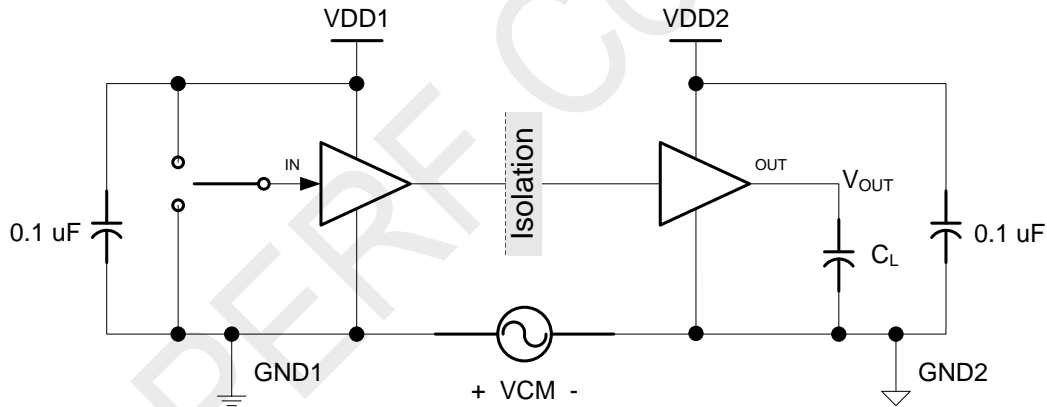

Figure 10. Common-Mode Transient Immunity Test Circuit

Notes:

1. $C_L = 15$ pF, the total instrumentation and connection is within $\pm 20\%$.

10 Electrical Specifications

10.1 Electrical Characteristics with 5 V Supply

VDD1 = VDD2 = 5V, T_A = -40 to 125 °C.

Table 5. Electrical Characteristics with 5 V Supply

Parameters	Symbol	Condition	Min.	Typ.	Max.	Unit
Power on reset	V _{POR}	POR threshold as during power-up		2.3		V
	V _{HYS}	POR threshold hysteresis		0.1		V
Input threshold	V _{IT}	Input threshold at rising edge			0.7*VDD1	V
	V _{IT-}	Input threshold at falling edge	0.3*VDD1			V
	V _{ITHYS}	Input threshold hysteresis		0.2*VDD1		V
High level output voltage	V _{OH}	I _{OH} = -4mA	VDD - 0.3			V
Low level output voltage	V _{OL}	I _{OL} = 4mA			0.3	V
Output impedance	R _O			50		Ω
Input pull high or low current	I _{pull}			10	15	μA
Start-up time after POR	tr _{bs}			10		μs
Common mode transient	CMTI			200		kV/μs

10.2 Supply Current Characteristics with 5 V Supply

VDD1 = VDD2 = 5V, T_A = -40 to 125 °C.

Table 6. Supply Current Characteristics with 5 V Supply

Parameter	Symbol	Typ.	Max.	Unit
CMT8020NXL				
Supply current EN = VDDI, V _{IN} = 0 V	I _{DD1}	0.67		mA
	I _{DD2}	1.14		mA
Supply current: device is disabled. EN = VDDI, V _{IN} = VDDI,	I _{DD1}	2.96		mA
	I _{DD2}	1.19		mA
Supply current: 1 Mbps square wave clock input AC signal. All channels switching with 1 Mbps square wave input, C _L = 15 pF	I _{DD1}	1.82		mA
	I _{DD2}	1.34		mA
Supply current: 10 Mbps square wave clock input AC signal. All channels switching with 10 Mbps square wave input, C _L = 15 pF	I _{DD1}	1.85		mA
	I _{DD2}	2.84		mA
CMT8021NXL				
Supply current EN = VDDI, V _{IN} = 0 V	I _{DD1}	1.12		mA
	I _{DD2}	1.14		mA
Supply current: device is disabled. EN = VDDI, V _{IN} = VDDI,	I _{DD1}	2.27		mA
	I _{DD2}	2.30		mA

Parameter	Symbol	Typ.	Max.	Unit
Supply current: 1 Mbps square wave clock input AC signal. All channels switching with 1 Mbps square wave input, $C_L = 15$ pF	I_{DD1}	1.79		mA
	I_{DD2}	1.83		mA
Supply current: 10 Mbps square wave clock input AC signal. All channels switching with 10 Mbps square wave input, $C_L = 15$ pF	I_{DD1}	2.21		mA
	I_{DD2}	2.25		mA
CMT8022NXL				
Supply current EN = VDDI, $V_{IN} = 0$ V	I_{DD1}	1.13		mA
	I_{DD2}	1.13		mA
Supply current: device is disabled. EN = VDDI, $V_{IN} = VDDI$,	I_{DD1}	2.35		mA
	I_{DD2}	2.30		mA
Supply current: 1 Mbps square wave clock input AC signal. All channels switching with 1 Mbps square wave input, $C_L = 15$ pF	I_{DD1}	1.83		mA
	I_{DD2}	1.82		mA
Supply current: 10 Mbps square wave clock input AC signal. All channels switching with 10 Mbps square wave input, $C_L = 15$ pF	I_{DD1}	2.25		mA
	I_{DD2}	2.24		mA

Table 7-1. Supply Current with 5 V Supply- Characteristics of CMT802XNXL

Parameters	Symbol	Condition	Min.	Typ.	Max.	Unit
Data rate	DR		0	5		Mbps
Minimum pulse width	PW	See figure 6, $C_L = 15$ pF		5	5	ns
Propagation delay rising	t_{PLH}	See figure 6, $C_L = 15$ pF		9	15	ns
Propagation delay falling	t_{PHL}	See figure 6, $C_L = 15$ pF		9	15	ns
Pulse width distortion $ t_{PHL} - t_{PLH} $	PWD	See figure 6, $C_L = 15$ pF			5	ns
Rising time	t_r	See figure 6, $C_L = 15$ pF			5	ns
Falling time	t_f	See figure 6, $C_L = 15$ pF			5	ns
Peak eye diagram Jitter	$t_{JIT}(PK)$			400		ps
Channel-to-channel delay Skew	$t_{SK}(C2C)$			1.5	2.5	ns
Part-to-part delay skew	$t_{SK}(P2P)$				5	ns

10.3 Supply Current Characteristics with 3.3 V Supply

$V_{DD1} = V_{DD2} = 3.3V$, $T_A = -40$ to 125 °C.

Table 8. Supply Current Characteristics with 3.3 V Supply

Parameter	Symbol	Typ.	Max.	Unit
CMT8020NXL				
Supply current EN = VDDI, $V_{IN} = 0$ V	I_{DD1}	0.67		mA
	I_{DD2}	1.14		mA
Supply current: device is disabled.	I_{DD1}	2.94		mA

Parameter	Symbol	Typ.	Max.	Unit
EN = VDDI, V _{IN} = VDDI,	I _{DD2}	1.18		mA
Supply current: 1 Mbps square wave clock input AC signal. All channels switching with 1 Mbps square wave input, C _L = 15 pF	I _{DD1}	1.80		mA
	I _{DD2}	1.27		mA
Supply current: 10 Mbps square wave clock input AC signal. All channels switching with 10 Mbps square wave input, C _L = 15 pF	I _{DD1}	1.83		mA
	I _{DD2}	2.26		mA
CMT8021NXL				
Supply current EN = VDDI, V _{IN} = 0 V	I _{DD1}	1.12		mA
	I _{DD2}	1.13		mA
Supply current: device is disabled. EN = VDDI, V _{IN} = VDDI,	I _{DD1}	2.25		mA
	I _{DD2}	2.29		mA
Supply current: 1 Mbps square wave clock input AC signal. All channels switching with 1 Mbps square wave input, C _L = 15 pF	I _{DD1}	1.71		mA
	I _{DD2}	1.75		mA
Supply current: 10 Mbps square wave clock input AC signal. All channels switching with 10 Mbps square wave input, C _L = 15 pF	I _{DD1}	2.01		mA
	I _{DD2}	2.05		mA
CMT8022NXL				
Supply current EN = VDDI, V _{IN} = 0 V	I _{DD1}	1.14		mA
	I _{DD2}	1.14		mA
Supply current: device is disabled. EN = VDDI, V _{IN} = VDDI,	I _{DD1}	2.33		mA
	I _{DD2}	2.31		mA
Supply current: 1 Mbps square wave clock input AC signal. All channels switching with 1 Mbps square wave input, C _L = 15 pF	I _{DD1}	1.75		mA
	I _{DD2}	1.74		mA
Supply current: 10 Mbps square wave clock input AC signal. All channels switching with 10 Mbps square wave input, C _L = 15 pF	I _{DD1}	2.04		mA
	I _{DD2}	2.03		mA

Table 9-1. Supply Current with 3.3 V Supply - Characteristics of CMT802XNXL

Parameters	Symbol	Condition	Min.	Typ.	Max.	Unit
Data rate	DR		0	5		Mbps
Minimum pulse width	PW	See figure 9, C _L = 15 pF		5		ns
Propagation delay rising	t _{PLH}	See figure 9, C _L = 15 pF		9	15	ns
Propagation delay falling	t _{PHL}	See figure 9, C _L = 15 pF		9	15	ns
Pulse width distortion t _{PHL} - t _{PLH}	PWD	See figure 9, C _L = 15 pF			5	ns
Rising time	t _r	See figure 9, C _L = 15 pF			5	ns
Falling time	t _f	See figure 9, C _L = 15 pF			5	ns
Peak eye diagram Jitter	t _{JIT(PK)}			400		ps
Channel-to-channel Delay Skew	t _{SK(c2c)}			2.5	2.5	ns
Part-to-part delay skew	t _{SK(p2p)}			5	5	ns

10.4 Supply Current Characteristics with 2.5 V Supply

VDD1 = VDD2 = 2.5 V, T_A = -40 to 125 °C.

Table 10. Supply Current Characteristics with 2.5 V Supply

Parameter	Symbol	Typ.	Max.	Unit
CMT8020NXL				
Supply current EN = VDDI, V _{IN} = 0 V	I _{DD1}	0.66		mA
	I _{DD2}	1.13		mA
Supply current: device is disabled. EN = VDDI, V _{IN} = VDDI,	I _{DD1}	2.93		mA
	I _{DD2}	1.18		mA
Supply current: 1 Mbps square wave clock input AC signal. All channels switching with 1 Mbps square wave input, C _L = 15 pF	I _{DD1}	1.79		mA
	I _{DD2}	1.24		mA
Supply current: 10 Mbps square wave clock input AC signal. All channels switching with 10 Mbps square wave input, C _L = 15 pF	I _{DD1}	1.82		mA
	I _{DD2}	2.00		mA
CMT8021NXL				
Supply current EN = VDDI, V _{IN} = 0 V	I _{DD1}	1.11		mA
	I _{DD2}	1.13		mA
Supply current: device is disabled. EN = VDDI, V _{IN} = VDDI,	I _{DD1}	2.24		mA
	I _{DD2}	2.28		mA
Supply current: 1 Mbps square wave clock input AC signal. All channels switching with 1 Mbps square wave input, C _L = 15 pF	I _{DD1}	1.65		mA
	I _{DD2}	1.69		mA
Supply current: 10 Mbps square wave clock input AC signal. All channels switching with 10 Mbps square wave input, C _L = 15 pF	I _{DD1}	1.86		mA
	I _{DD2}	1.90		mA
CMT8022NXL				
Supply current EN = VDDI, V _{IN} = 0 V	I _{DD1}	1.14		mA
	I _{DD2}	1.13		mA
Supply current: device is disabled. EN = VDDI, V _{IN} = VDDI,	I _{DD1}	2.32		mA
	I _{DD2}	2.30		mA
Supply current: 1 Mbps square wave clock input AC signal. All channels switching with 1 Mbps square wave input, C _L = 15 pF	I _{DD1}	1.74		mA
	I _{DD2}	1.72		mA
Supply current: 10 Mbps square wave clock input AC signal. All channels switching with 10 Mbps square wave input, C _L = 15 pF	I _{DD1}	1.94		mA
	I _{DD2}	1.92		mA

Table 11-1. Supply Current with 2.5 V Supply - Characteristics of CMT802XNXL

Parameters	Symbol	Condition	Min.	Typ.	Max.	Unit
Data rate	DR		0	5		Mbps
Minimum pulse width	PW	See figure 9, C _L = 15 pF		5	5	ns
Propagation delay rising	t _{PLH}	See figure 9, C _L = 15 pF		9	15	ns
Propagation delay falling	t _{PHL}	See figure 9, C _L = 15 pF		9	15	ns
Pulse width distortion t _{PHL} - t _{PLH}	PWD	See figure 9, C _L = 15 pF			5	ns

Parameters	Symbol	Condition	Min.	Typ.	Max.	Unit
Rising time	t_r	See figure 9, $C_L = 15$ pF			5	ns
Falling time	t_f	See figure 9, $C_L = 15$ pF			5	ns
Peak eye diagram Jitter	$t_{JIT}(PK)$			400		ps
Channel-to-channel Delay Skew	$t_{SK}(c2c)$			2.5	2.5	ns
Part-to-part delay skew	$t_{SK}(p2p)$			5	5	ns

HOPERF Confidential

10.5 Typical Characteristics

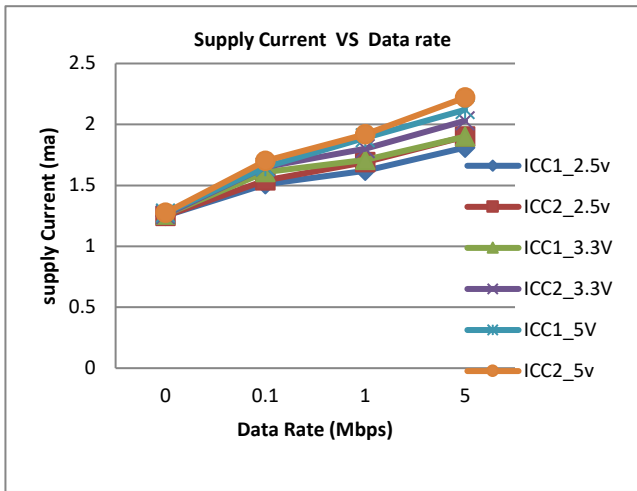

Figure 11. Supply Current vs. Data Rate (with 15-pF Load) $T_A=25^{\circ}\text{C}$ $C_L=15\text{pF}$

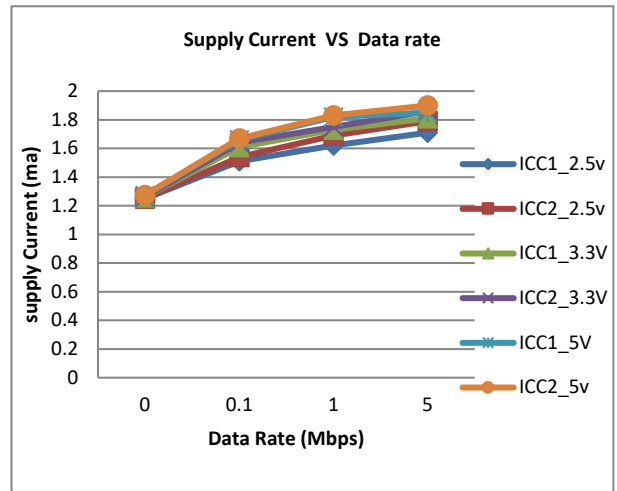

Figure 12. Supply Current vs. Data Rate (with No Load) $T_A=25^{\circ}\text{C}$ $C_L=\text{No Load}$

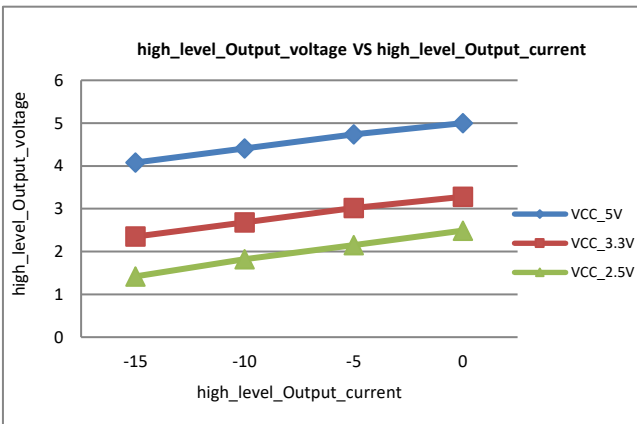

Figure 13. High-Level Output Voltage vs. High-Level Output Current ($T_A=25^{\circ}\text{C}$)

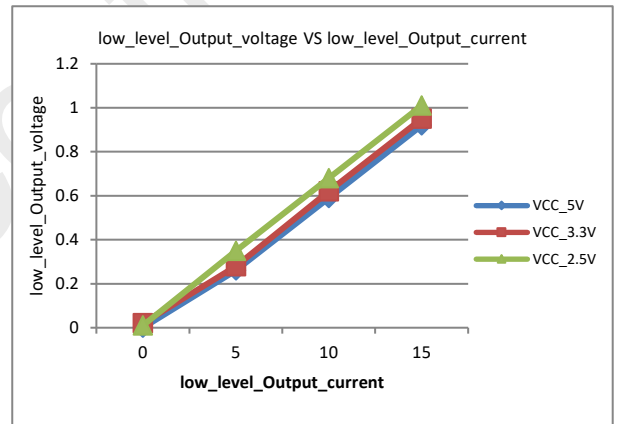

Figure 14. Low-Level Output Voltage vs. Low-Level Output Current ($T_A=25^{\circ}\text{C}$)

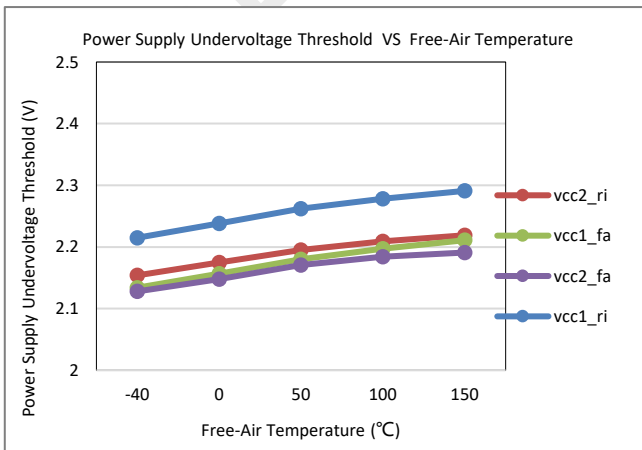

Figure 15. Power Supply Under-voltage Threshold vs. Free-Air Temperature

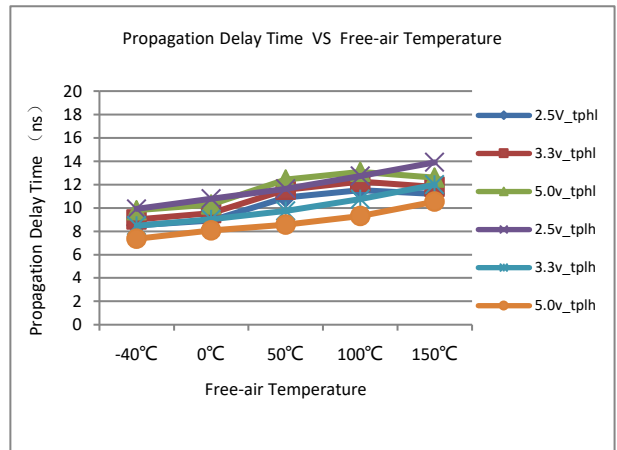

Figure 16. Propagation Delay Time vs. Free-Air Temperature

10.6 Insulation Specifications

Table 12. Insulation Specifications

Parameters	Sym.	Condition	Value	Unit
			NB SOIC-8	
External clearance ^[1]	CLR	The shortest terminal-to-terminal distance through air	4.0	mm
External creepage ^[1]	CRP	The shortest terminal-to-terminal distance across the package surface	4.0	mm
Distance through insulation	DTI	Minimum internal gap	20	um
Comparative tracking index	CTI	DIN EN 60112 (VDE 0303-11); IEC 60112	> 400	V
Material group	-		II	-
Overvoltage category per IEC 60664-1	-	Rated mains voltage $\leq 300 V_{RMS}$	I	-
		Rated mains voltage $\leq 600 V_{RMS}$	I-IV	-
		Rated mains voltage $\leq 1000 V_{RMS}$	I-III	-
DIN VDE V 0884-11:2017-01^[2]				
Maximum repetitive isolation voltage	V_{IORM}		565	V_{pk}
Maximum isolation working voltage	V_{IOWM}	AC voltage (sine wave); Time dependent dielectric breakdown (TDDB) test	400	V_{RMS}
		DC voltage	565	V_{DC}
Maximum transient isolation voltage	V_{IOTM}	$V_{TEST} = V_{IOTM}$, $t = 60$ s (qualification); $t = 1$ s (100% production)	5300	V_{pk}
Maximum surge isolation voltage ^[3]	V_{IOSM}	Test method per IEC60065, 1.2/50 us waveform, $V_{TEST} = 1.6 \times V_{IOSM}$ (qualification)	5384	V_{pk}
Apparent charge ^[4]	q_{pd}	Method a: After I/O safety test subgroup 2/3, $V_{ini} = V_{IOTM}$, $t_{ini} = 60$ s; $V_{pd(m)} = 1.2 \times V_{IORM}$, $t_m = 10$ s	≤ 5	$\leq 5pC$
		Method a: After environmental tests subgroup 1, $V_{ini} = V_{IOTM}$, $t_{ini} = 60$ s; $V_{pd(m)} = 1.6 \times V_{IORM}$, $t_m = 10$ s	≤ 5	
		Method b1: At routine test (100% production) and preconditioning (type test) $V_{ini} = V_{IOTM}$, $t_{ini} = 1$ s; $V_{pd(m)} = 1.875 \times V_{IORM}$, $t_m = 1$ s	≤ 5	
Isolation capacitance, input to output ^[5]	C_{IO}	$V_{IO} = 0.4 \times \sin(2\pi ft)$, $f = 1$ MHz	0.6	pF
Isolation resistance, input to output ^[5]	R_{IO}	$V_{IO} = 500$ V	$>10^{10}$	Ω
Withstand isolation voltage	V_{ISO}	$V_{TEST} = V_{ISO}$, $t = 60$ s (qualification); $V_{TEST} = 1.2 \times V_{ISO}$, $t = 1$ s (100% production)	3750	V_{RMS}

Notes:

- [1]. Creepage and clearance requirements should be applied according to the specific equipment isolation standards of an application. Care should be taken to maintain the creepage and clearance distance of a board design to ensure that the mounting pads of the isolator on the printed-circuit board do not reduce this distance. Creepage and clearance on a printed-circuit board become equal in certain cases. Techniques such as inserting grooves and/or ribs on a printed-circuit board are used to help increase these specifications.
- [2]. This coupler is suitable for safe electrical insulation only within the safety ratings. Compliance with the safety ratings shall be ensured by means of suitable protective circuits.
- [3]. Testing is carried out in air or oil to determine the intrinsic surge immunity of the isolation barrier.
- [4]. Apparent charge is electrical discharge caused by a partial discharge (pd).
- [5]. All pins on each side of the barrier are tied together creating a two-terminal device.

HOPERF Confidential

10.7 Safety-related Certifications

Table 13. Safety-related Certifications

VDE	CSA	UL	CQC	TUV
DIN VDE V0884-11:2017-01 (Patents pending)	IEC 60950-1, IEC 62368-1 and IEC 61010-1 (Patents pending)	Recognized under UL 1577 Component Recognition Program (Patents pending)	GB 4943.1-2011	EN 61010-1:2010 (3rd Ed) and EN 60950-1:2006/A2: 2013 (Patents pending)
Certificate number: pending	Master contract number: pending	File number: pending	Certificate number: CQC11-471543-2022	Client ID number: pending

10.8 Safety Limiting Values

Safety limiting intends to minimize potential damage to the isolation barrier upon failure of input or output circuitry. A failure of the I/O can allow low resistance to ground or the supply and, without current limiting, dissipate sufficient power to overheat the die and damage the isolation barrier potentially leading to secondary system failures

Table 14. Safety Limiting Values

Parameters	Symbol	Test Condition	Value	Unit
			NB SOIC-16	
Safety input, output, or supply current	Is	$R_{\theta JA} = 140 \text{ }^\circ\text{C/W}$, $V_I = 5.5 \text{ V}$, $T_J = 125 \text{ }^\circ\text{C}$, $T_A = 25 \text{ }^\circ\text{C}$	160	mA
		$R_{\theta JA} = 84 \text{ }^\circ\text{C/W}$, $V_I = 5.5 \text{ V}$, $T_J = 125 \text{ }^\circ\text{C}$, $T_A = 25 \text{ }^\circ\text{C}$		mA
Total power dissipation at 25°C	Ps			W
Case temperature	Ts		125	°C

10.9 Thermal Information

Table 15. Thermal Information

Parameter	Symbol	Value		Unit
		NB SOIC-16	WB SOIC-16	
Junction-to-ambient thermal resistance	θ_{JA}	78.9	78.9	°C/W
Junction-to-case (top) thermal resistance	$\theta_{JC (top)}$	41.1	41.6	°C/W
Junction-to-board thermal resistance	θ_{JB}	49.5	43.6	°C/W

11 Function Description

11.1 Function Overview

The CMT802XNXL device is a high-performance, quad-channel digital isolator with 3750 V_{RMS} isolation rating. The CMT802XNXL has an On-Off keying (OOK) modulation scheme to transmit the digital data across a silicon dioxide based isolation barrier. The transmitter sends a high-frequency carrier across the barrier to represent one digital state and sends no signal to represent the other digital state. The receiver demodulates the signal after advanced signal conditioning and produces the output through a buffer stage. If the EN_x pin is low then the output goes to high impedance. The CMT802XNXL also incorporates advanced circuit techniques to maximize the CMTI performance and minimize the radiated emissions due to the high frequency carrier and IO buffer switching. The figure below shows a conceptual detail of how the On-Off keying scheme works.

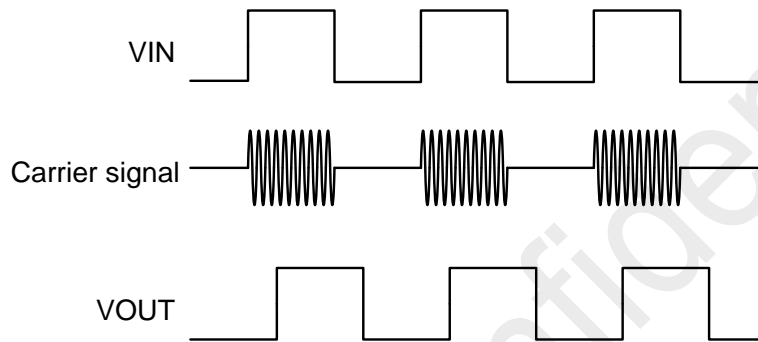

Figure 17. On-Off Keying Based Modulation Scheme

11.2 Functional Modes

The table below lists the functional modes of the CMT802XNXL.

Table 16. Function Table^[1]

VDD1	VDD2	Input (IN _x) ^[2]	Output (OUT _x)	Comment
PU	PU	H	H	Normal operation: A channel output assumes the logic state of its input
		L	L	
		Open	Default	Default mode: when IN _x is open, the corresponding channel output goes to its default logic state
PD	PU	X	Default	Default mode: when VDD1 is unpowered, a channel output assumes the logic state based on the selected default option. When VDD1 transitions from unpowered to powered-up, a channel output assumes the logic state of the input. When VDD1 transitions from powered-up to unpowered, channel output assumes the selected default state
X	PD	X	Undetermined	When VDD2 is unpowered, a channel output is undetermined ^[3] . When VDD2 transitions from unpowered to powered-up, a channel output assumes the logic state of the input

11.3 Insulation Lifetime

Insulation lifetime projection data is collected by using industry-standard Time Dependent Dielectric Breakdown (TDDB) test method. In this test, all pins on each side of the barrier are tied together creating a two-terminal device and high voltage applied between the two sides; See the figure below for TDDB test setup. The insulation breakdown data is collected at various high voltages switching at 60 Hz over temperature. For reinforced insulation, VDE standard requires the use of TDDB projection line

with failure rate of less than 1 part per million (ppm). Even though the expected minimum insulation lifetime is 20 years at the specified working isolation voltage, VDE reinforced certification requires additional safety margin of 20% for working voltage and 87.5% for lifetime which translates into minimum required insulation lifetime of 37.5 years at a working voltage that's 20% higher than the specified value.

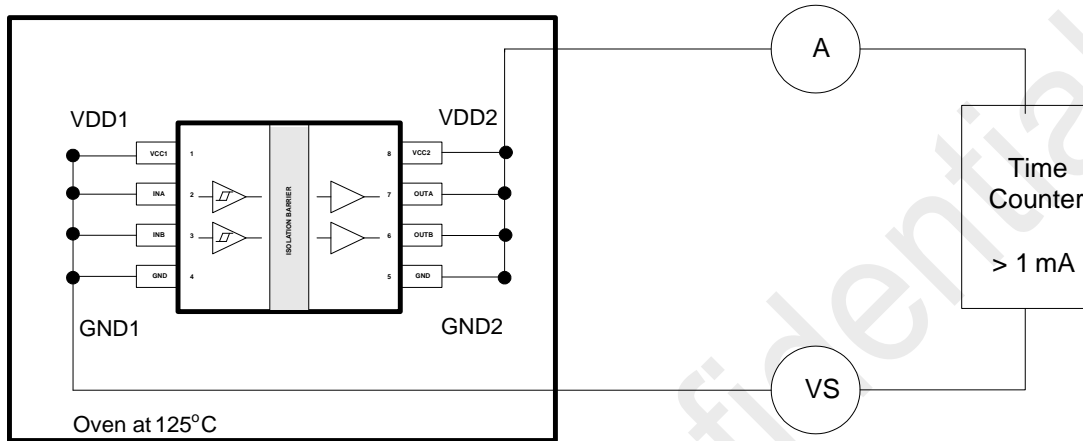

Figure 18. Test Setup for Insulation Lifetime Measurement

12 Packaging Information

The packaging information of the CMT802XNXL is shown in the figures below.

12.1 CMT802XNXL Narrow Body SOIC-8 Packaging

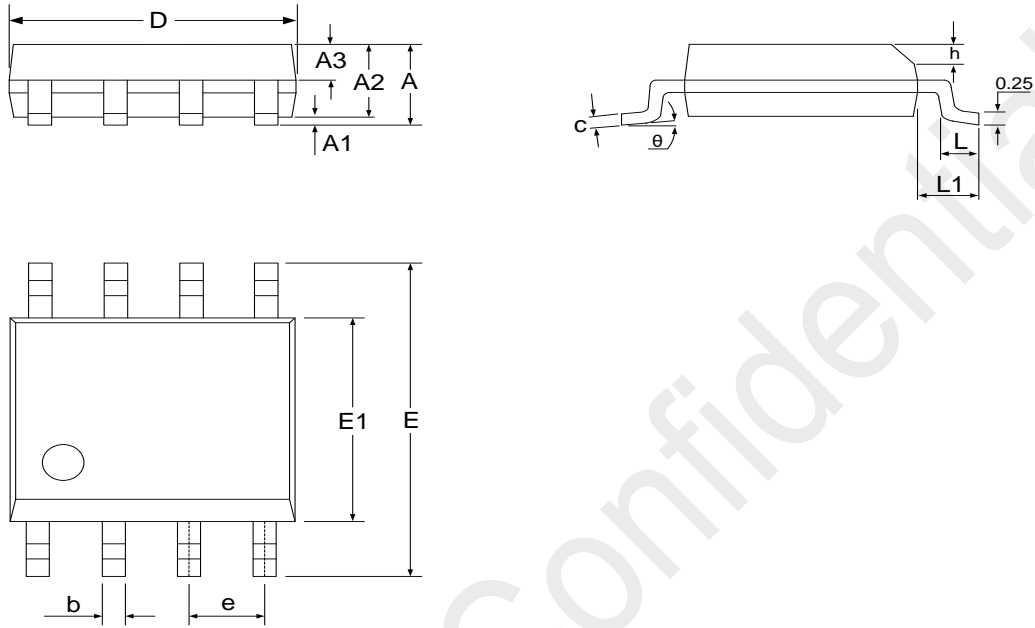

Figure 19. Narrow Body SOIC-8 Packaging

Table 17. Narrow Body SOIC-8 Packaging Scale

Symbol	Scale (mm)		
	Min.	Typ.	Max.
A	-	-	1.75
A1	0.10	-	0.225
A2	1.30	1.40	1.50
A3	0.60	0.65	0.70
b	0.39	-	0.48
c	0.21	-	0.26
D	4.70	4.90	5.10
E	5.80	6.00	6.20
E1	3.70	3.90	4.10
e	1.27 BSC		
h	0.25	-	0.50
L	0.50	-	0.80
L1	1.05 BSC		
θ	0	-	8°

13 Ordering Information

Table 18. Part Number List

Part Number	Min. Order Quantity	Withstand Voltage (rms)	Numbers of Total Channels	Digital Rate (MHz)	Default Output State	Package
CMT8020N0L	3000	3750	2	5	Low	NB SOIC-8
CMT8020N1L	3000	3750	2	5	High	NB SOIC-8
CMT8021N0L	3000	3750	2	5	Low	NB SOIC-8
CMT8021N1L	3000	3750	2	5	High	NB SOIC-8
CMT8022N0L	3000	3750	2	5	Low	NB SOIC-8
CMT8022N1L	3000	3750	2	5	High	NB SOIC-8

Part Number Naming Rule:

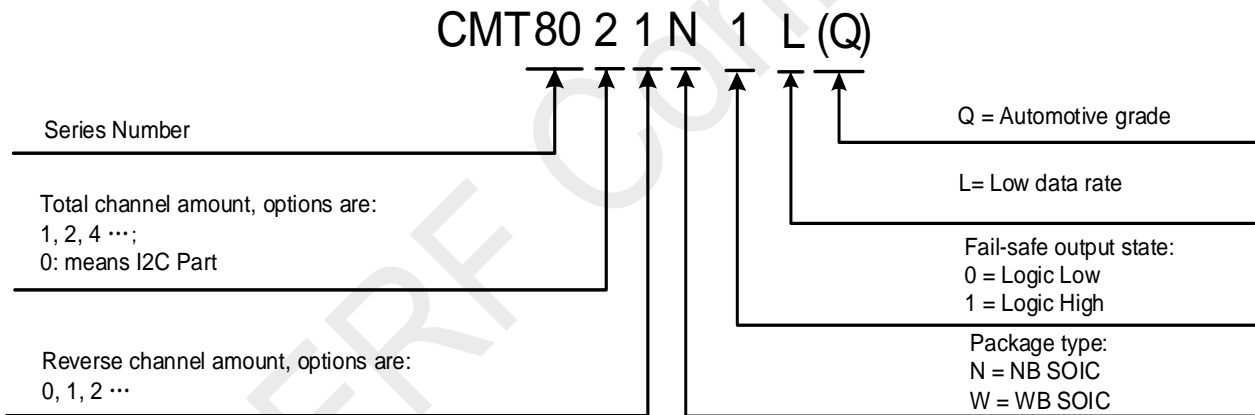

Please visit www.hoperf.com for more product/product line information.

Please contact sales@hoperf.com or your local sales representative for sales or pricing requirements.

14 Tape and Reel Information

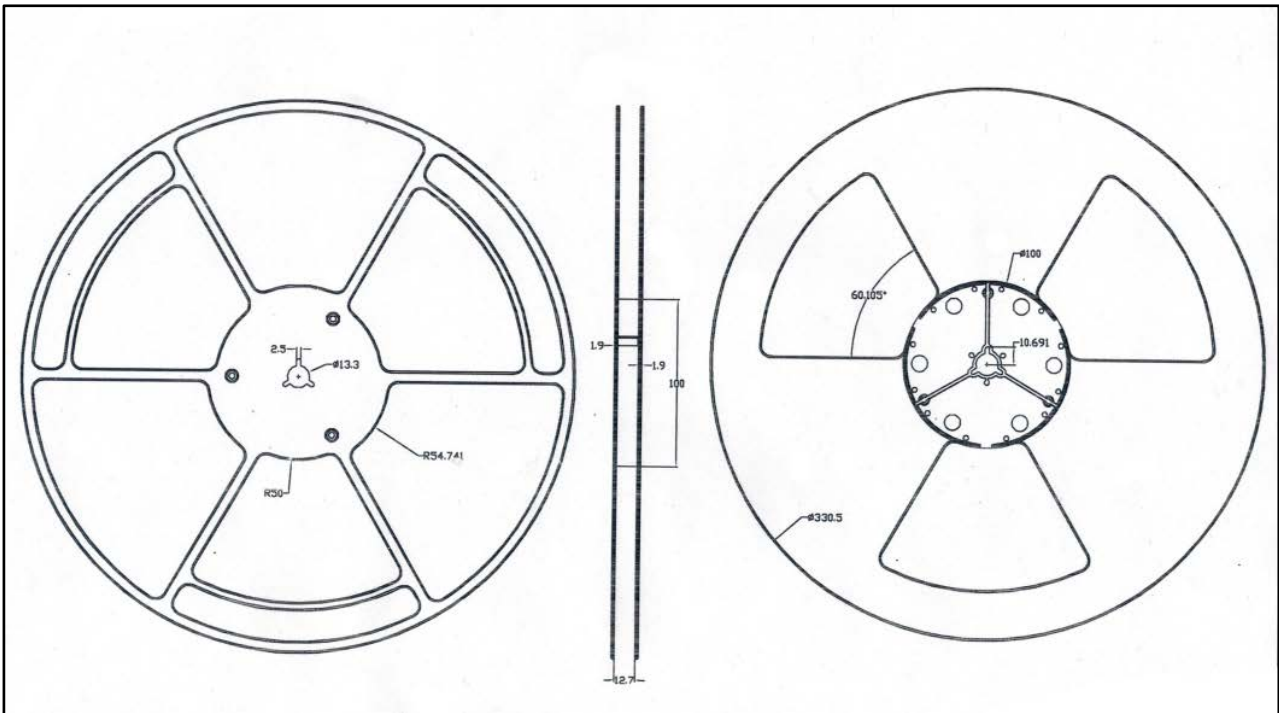

Figure 22. CMT802XNXL SOIC-8 Tape & Reel Information

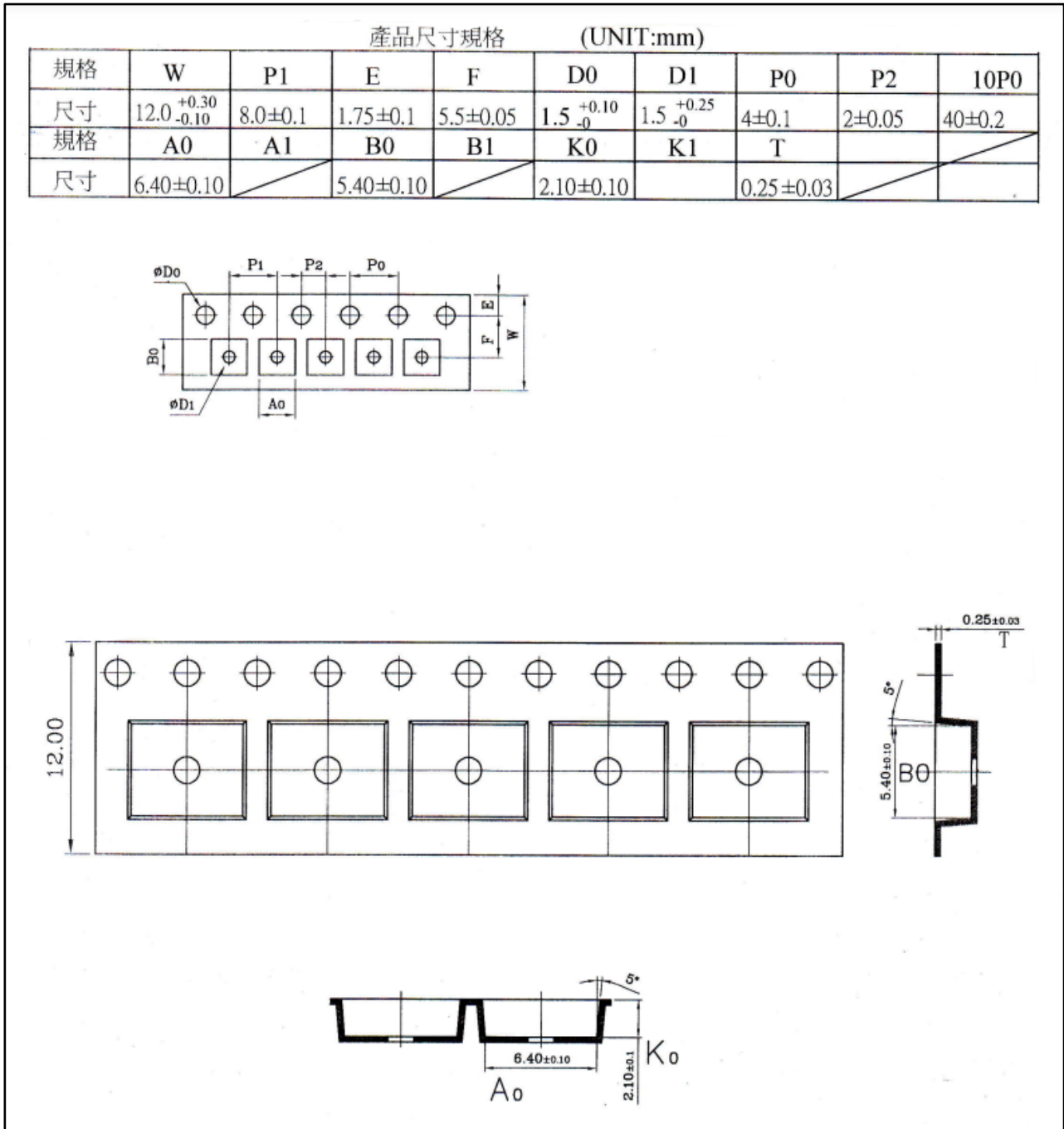

Figure 23. CMT802XNXL SOIC-8 Tape & Reel Information

15 Revise History

Table 19. Revise Record

Version No.	Chapter	Description	Date
0.1	All	Initial version	2023/03/23
0.2	All	Delete the silver printing section	2023/04/20
		Added the CQC certificate number	
0.3	All	Modified the data rate of 5 Mbps to 10 Mbps.	2023/11/28

HOPERF Confidential

16 Contacts

Shenzhen Hope Microelectronics Co., Ltd.

Address: 30th floor of 8th Building, C Zone, Vanke Cloud City, Xili Sub-district, Nanshan, Shenzhen, GD, P.R. China

Tel: +86-755-82973805 / 4001-189-180

Fax: +86-755-82973550

Post Code: 518052

Sales: sales@hoperf.com

Website: www.hoperf.com

Copyright. Shenzhen Hope Microelectronics Co. Ltd. All rights are reserved.

The information furnished by HOPERF is believed to be accurate and reliable. However, no responsibility is assumed for inaccuracies and specifications within this document are subject to change without notice. The material contained herein is the exclusive property of HOPERF and shall not be distributed, reproduced, or disclosed in whole or in part without prior written permission of HOPERF. HOPERF products are not authorized for use as critical components in life support devices or systems without express written approval of HOPERF. The HOPERF logo is a registered trademark of Shenzhen Hope Microelectronics Co., Ltd. All other names are the property of their respective owners.