

# RFM6601W-868S2 Transceiver Module Datasheet



## 1. Overview

The RFM6601 module includes a general wireless communication SoC, integrated with RF transceiver and a 32-bit RISC MCU. The MCU uses ARM Cortex M4, with 48 MHz operation frequency. The RF Transceiver has continuous frequency coverage from 868 MHz to 868.2 MHz.

The RFM6601W-868S2 Module provides ultra-long range and ultra-low power communication for wireless alarm applications. RFM6601W-868S2 can achieve a high sensitivity to -138 dBm and the maximum transmit power is up to +2 dBm. This makes the module suitable to be used in long range and have high efficiency.

## 2. Features

- Working Voltage: 1.7V - 3.7V
- Working Frequency: 868 MHz to 868.2 MHz
- Receiving Sensitivity: -138 dBm @SF=12, BW=125KHz
- Tx Current: 20mA @+2dbm (3.3V)
- Rx Current: 10mA @868.1 MHz

## 3. Applications

- Security Alarms
- Automatic distress signal system

### 4. Pin Diagram

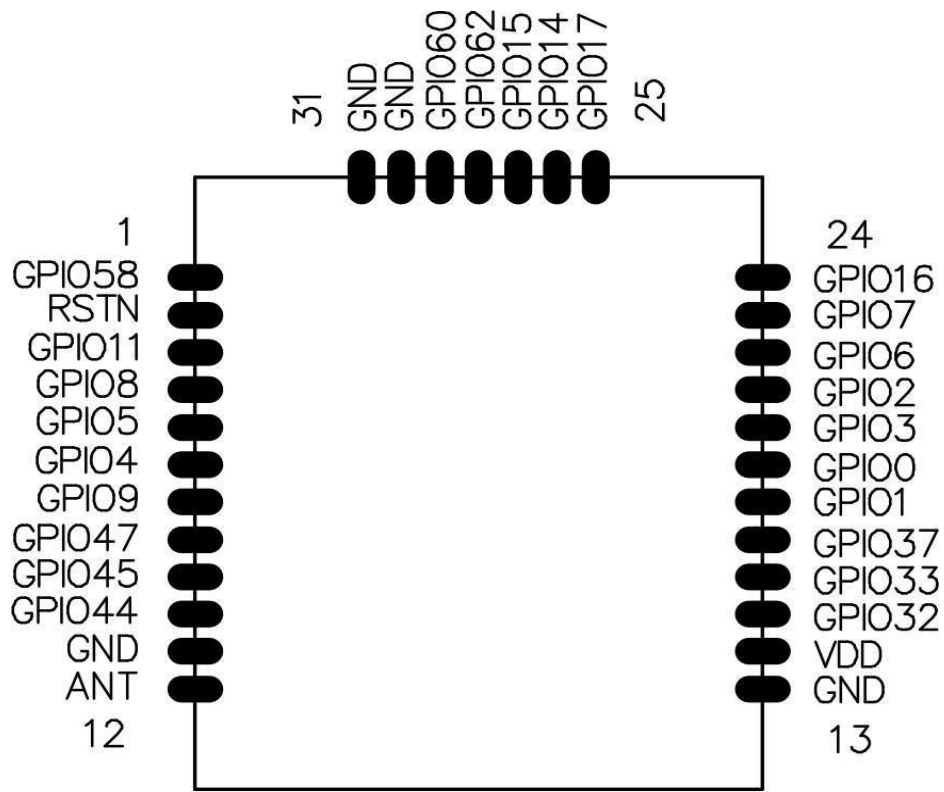

**Figure 1. Pin Diagram Top View**



**Table 1. RFM6601W-868S2 Module Pin Description**

Pin	Name	Description
1	GPIO58	MCU GPIO
2	RSTN	Reset signal, active low
3	GPIO11	MCU GPIO
4	GPIO08	MCU GPIO
5	GPIO05	MCU GPIO
6	GPIO04	MCU GPIO
7	GPIO09	MCU GPIO
8	GPIO47	MCU GPIO
9	GPIO45	MCU GPIO
10	GPIO44	MCU GPIO
11, 13, 30, 31	GND	Ground
12	ANT	Antenna port
14	VCC	Input voltage
15	GPIO32	MCU GPIO
16	GPIO33	MCU GPIO
17	GPIO37	MCU GPIO
18	GPIO1	MCU GPIO
19	GPIO0	MCU GPIO
20	GPIO3	MCU GPIO
21	GPIO2	MCU GPIO
22	GPIO6	SWD DATA
23	GPIO7	SWD CLK
24	GPIO16	MCU GPIO
<b>25</b>	<b>GPIO17</b>	<b>MCU GPIO (UART_TXD)</b>
26	GPIO14	MCU GPIO
27	GPIO15	MCU GPIO
<b>28</b>	<b>GPIO62</b>	<b>MCU GPIO (UART_RXD)</b>
29	GPIO60	MCU GPIO

## 5. Electrical Characteristics

Testing Conditions: 3.3V @ 25°C

**Table 2. Electrical Characteristics**

Parameters	Symbol	Conditions	Min.	Typ.	Max.	Unit
Frequency	Fc	RFM6601-868S2 (for Europe Local Market)	868.0	868.1	868.2	MHz
Receiving Sensitivity	S	Mode SF=12, BW=125KHz		-138		dBm
Working Voltage	V <sub>DD</sub>		1.7	3.3	3.7	V
Rx Current	I <sub>RX</sub>	868.1 MHz		10	11	mA
Tx Current	I <sub>TX</sub>	868.1 MHz @+2dbm		20	22	mA
Sleep Current	I <sub>sleep</sub>	Without RF and RTC		1.3		uA
Operating Temperature	T <sub>OP</sub>		-40		+85	°C

## 6. Dimension (Unit: mm)

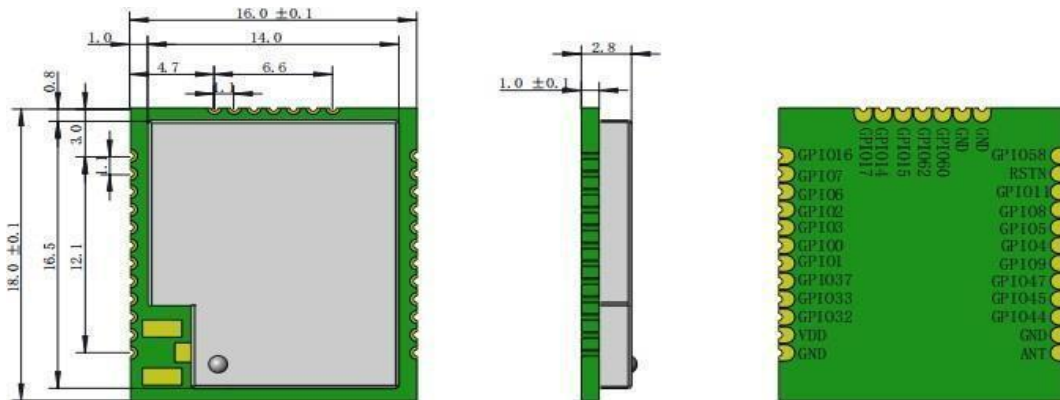

**Figure 2. Module Dimension**

## 7. Ordering Information

Model	Frequency
RFM6601-868S2 (for Europe)	868...868.2MHz

## 8. Revision History

**Table 3. Revision History Records**

Version	Description	Date
1.0	Initial Release	2021-11-15
1.11	Update module dimension and ordering information	2022-07-18
1.12	Update module photo and FCC, CE, IC certification information	2022-12-19
1.13L	Update module information for local market	2023-01-20

## 9. Contact Information

**Shenzhen Hope Microelectronics Co., Ltd.**

**Add:** 30th floor of 8th Building, C Zone, Vanke Cloud City, Xili Sub-district, Nanshan, Shenzhen, GD, P.R. China

**Tel:** +86-755-82973805

**Email:** [sales@hoperf.com](mailto:sales@hoperf.com)

**Website:** [www.hoperf.com](http://www.hoperf.com)

**NOTE:**

**(OEM) Integrator has to assure compliance of the entire end-product incl. the integrated RF Module. For 15 B (§15.107 and if applicable §15.107) compliance, the host manufacturer is required to show compliance with 15 while the module is installed and operating.**

**Furthermore, the module should be transmitting and the evaluation should confirm that the module's intentional emissions (15C) are compliant (fundamental / out-of-band). Finally, the integrator has to apply the appropriate equipment authorization (e.g. Verification) for the new host device per definition in §15.101.**

**Integrator is reminded to assure that these installation instructions will not be made available to the end-user of the final host device.**

**The final host device, into which this RF Module is integrated “has to be labelled with an auxiliary label stating the FCC ID of the RF Module, such as” Contains FCC ID: 2ASEO-RFM6601**

**"This device complies with part 15 of the FCC rules. Operation is subject to the following two conditions:**

- (1) this device may not cause harmful interference, and**
- (2) this device must accept any interference received, including interference that may cause undesired operation."**

**NOTE:**

**This equipment has been tested and found to comply with the limits for a Class B digital device, pursuant to part 15 of the FCC Rules. These limits are designed to provide reasonable protection against harmful interference in a residential installation. This equipment generates, uses and can radiate radio frequency energy and, if not installed and used in accordance with the instructions, may cause harmful interference to radio communications. However, there is no guarantee that interference will not occur in a particular installation. If this equipment does cause harmful interference to radio or television reception, which can be determined by turning the equipment off and on, the user is encouraged to try to correct the interference by one or more of the following measures:**

- Reorient or relocate the receiving antenna.**
- Increase the separation between the equipment and receiver.**
- Connect the equipment into an outlet on a circuit different from that to which the receiver is connected.**
- Consult the dealer or an experienced radio/TV technician for help.**

**Changes or modifications to this unit not expressly approved by the party responsible for compliance could void the user's authority to operate the equipment.**



Additionally, this module was tested with a detachable antenna. The specification of rubber rod antenna are as follows:

- (1) Frequency Range (MHz):  $915 \pm 10$ ;
- (2) V.S.W.R:  $\leq 1.5$ ;
- (3) Input Impedance ( $\Omega$ ): 50;
- (4) Gain (dBi): 2.15;

#### Module Statement

The single-modular transmitter is a self-contained, physically delineated, component for which compliance can be demonstrated independent of the host operating conditions, and which complies with all eight requirements of §15.212(a)(1) as summarized below.

- 1) The radio elements have the radio frequency circuitry shielded.
- 2) The module has buffered modulation/data inputs to ensure that the device will comply with Part 15 requirements with any type of input signal.
- 3) The modular transmitter has its own power supply regulation.
- 4) The module contains a PR-SMA antenna.
- 5) The module demonstrates compliance in a stand-alone configuration.
- 6) The module is labeled with its permanently affixed FCC ID label.
- 7) The module complies with all specific rules applicable to the transmitter, including all the conditions provided in the integration instructions by the grantee.
- 8) The module complies with RF exposure requirements.

This transmitter/module must not be collocated or operating in conjunction with any other antenna or transmitter.

#### NOTE:

This device complies with Innovation, Science and Economic Development Canada's (ISED)'s license-exempt RSSs. Operation is subject to the following two conditions:

- (1) This device may not cause interference; and
- (2) This device must accept any interference, including interference that may cause undesired operation of the device.

The equipment complies with ISED radiation exposure limits set forth for an uncontrolled environment.

The ISED certification label of a module shall be clearly visible at all times when installed in the host product; otherwise, the host product must be labelled to display the ISED certification number for the module, preceded by the word "contains" or similar wording expressing the same meaning, as follows:

Contains IC: 24999-RFM6601

**NOTE:**

**Cet appareil est conforme aux CNR exemptes de licence d'Industrie Canada.**

**Son fonctionnement est soumis aux deux conditions suivantes:**

- (1) Ce dispositif ne peut causer d'interférences; et**
- (2) Ce dispositif doit accepter toute interférence, y compris les interférences qui peuvent causer un mauvais fonctionnement de l'appareil.**

**Host manufacturer is strongly recommended to confirm compliance with FCC/ISED requirements for the transmitter when the module is installed in the host.**